



# Signal Generator

**R&S® SMC100A**

1411.4002K02



**Dear Customer,**

throughout this manual, the Signal Generator R&S® SMC100A is abbreviated as R&S SMC.

The firmware of the instrument makes use of the operating system LINUX® and other valuable open source software packages. The most important of them are listed below together with their corresponding open source license. The verbatim license texts are provided on the user documentation CD-ROM (included in delivery).

<b>Package</b>	<b>Link</b>	<b>License</b>
LINUX® Kernel	<a href="http://www.linux.org/">http://www.linux.org/</a>	GPL 2
glibc	<a href="http://www.gnu.org/software/libc/">http://www.gnu.org/software/libc/</a>	LGPL
busybox	<a href="http://www.busybox.net/">http://www.busybox.net/</a>	GPL 2
OpenSSL	<a href="http://www.openssl.org/">http://www.openssl.org/</a>	OpenSSL / SSLeay
XFree86	<a href="http://www.xfree86.org/">http://www.xfree86.org/</a>	XFree86
Xitami	<a href="http://www.xitami.com">http://www.xitami.com</a>	NetSnmp-5.0.8
PHP	<a href="http://www.php.net">http://www.php.net</a>	2.5b6
OpenSSL	<a href="http://www.openssl.org">http://www.openssl.org</a>	BSD
BOOST Library	<a href="http://www.boost.org">http://www.boost.org</a>	Artistic
zlib	<a href="http://www.zlib.net">http://www.zlib.net</a>	Boost Software, v.1
PC/SC-Lite	<a href="http://www.linuxnet.com/">http://www.linuxnet.com/</a>	ACE_TAO

The OpenSSL Project for use in the OpenSSL Toolkit (<http://www.openssl.org/>), includes cryptographic software written by Eric Young (eay@cryptsoft.com) and software written by Tim Hudson (tjh@cryptsoft.com).

LINUX® is a trademark of Linus Torvalds.

Rohde & Schwarz would like to thank the open source community for their valuable contribution to embedded computing.

R&S® is a registered trademark of Rohde & Schwarz GmbH & Co. KG. Trade names are trademarks of the owners.

## **Chapter Overview**

### **Index**

**Safety Instructions**

**Customer Information Regarding Product Disposal**

**Certificate of Quality**

**Customer Support**

**List of R&S Representatives**

**Procedure in Case of Service and Ordering of Spare Parts**

**Contents of Service Manual for the Signal Generator R&S SMC100A**

**Chapter 1: Performance Test**

**Chapter 2: Procedures after Module Replacement**

**Chapter 3: Repair**

**Chapter 4: Software Update / Installing Options**

**Chapter 5: Documents**



# Index

## A

Adjustments .....	2.1
Amplitude modulation	
Test procedure .....	1.24, 1.29

## B

Boot problems	
troubleshooting .....	3.10

## C

Check	
Rated characteristics .....	1.1
Check Front Panel .....	3.11

## D

Debug Page .....	3.13
Documents .....	5.1

## F

Fan does not work .....	3.9
Firmware update .....	4.1
Frequency	
Test procedure .....	1.8
Frequency Error .....	3.25, 3.27
Fuses .....	3.32

## I

Internal Adjustments .....	3.15
----------------------------	------

## L

Level	
Test procedure .....	1.18

## M

Measuring equipment	
troubleshooting .....	3.6
Modulation	
Analog Test assembly .....	1.2, 1.3
Modulation generator	
Test procedure .....	1.22
Module replacement .....	3.28
Modules overview .....	3.28
Motherboard .....	3.4

## O

Option	
installation .....	4.2
list .....	4.2
Output impedance	
Test assembly .....	1.4

## P

Phase noise	
Test assembly .....	1.4
Power cables .....	5.2
Power Supply Module .....	3.4
Protection service functions .....	3.13
Pulse modulation	
Test procedure .....	1.36

## R

Rated characteristics	
Checking .....	1.1
Test procedures .....	1.7
Reference frequency	
Test procedure .....	1.7
Replacement	
module .....	3.28
Replacing Fuses .....	3.32
Residual	
AM Test assembly .....	1.3

## S

Software update .....	4.1
Spectral purity	
Test procedure .....	1.11
Switch-on problems .....	3.8

## T

Test assembly .....	1.2, 1.3
Analog modulations .....	1.2, 1.3
Output impedance .....	1.4
Residual AM .....	1.3
SSB phase noise .....	1.4
Test equipment .....	1.1
Test frequency (recommended) .....	1.6
Test Points .....	3.13
Test procedure	
Amplitude modulation .....	1.24, 1.29
Frequency .....	1.8
Level .....	1.18
Modulation generator .....	1.22
Pulse modulation .....	1.36
Spectral purity .....	1.11
Test procedures .....	1.7
Troubleshooting	
problems with booting .....	3.10
switch-on problems .....	3.8
test points and debug page .....	3.13
Troubleshooting – Internal Adjustments .....	3.15

## U

Unit cannot be switched on .....	3.8
Update of firmware .....	4.1
Update of software .....	4.1



# Grouped Safety Messages









## Make sure to read through and observe the following safety instructions!







All plants and locations of the Rohde & Schwarz group of companies make every effort to keep the safety standard of our products up to date and to offer our customers the highest possible degree of safety. Our products and the auxiliary equipment required for them are designed and tested in accordance with the relevant safety standards. Compliance with these standards is continuously monitored by our quality assurance system. The product described here has been designed and tested in accordance with the EC Certificate of Conformity and has left the manufacturer's plant in a condition fully complying with safety standards. To maintain this condition and to ensure safe operation, observe all instructions and warnings provided in this manual. If you have any questions regarding these safety instructions, the Rohde & Schwarz group of companies will be happy to answer them.

Furthermore, it is your responsibility to use the product in an appropriate manner. This product is designed for use solely in industrial and laboratory environments or, if expressly permitted, also in the field and must not be used in any way that may cause personal injury or property damage. You are responsible if the product is used for an intention other than its designated purpose or in disregard of the manufacturer's instructions. The manufacturer shall assume no responsibility for such use of the product.

The product is used for its designated purpose if it is used in accordance with its product documentation and within its performance limits (see data sheet, documentation, the following safety instructions). Using the product requires technical skills and a basic knowledge of English. It is therefore essential that only skilled and specialized staff or thoroughly trained personnel with the required skills be allowed to use the product. If personal safety gear is required for using Rohde & Schwarz products, this will be indicated at the appropriate place in the product documentation. Keep the basic safety instructions and the product documentation in a safe place and pass them on to the subsequent users.

### Symbols and safety labels

							
Observe product documentation	Weight indication for units >18 kg	Danger of electric shock	Warning! Hot surface	PE terminal	Ground	Ground terminal	Attention! Electrostatic sensitive devices

					
Supply voltage ON/OFF	Standby indication	Direct current (DC)	Alternating current (AC)	Direct/alternating current (DC/AC)	Device fully protected by double/reinforced insulation

Observing the safety instructions will help prevent personal injury or damage of any kind caused by dangerous situations. Therefore, carefully read through and adhere to the following safety instructions before putting the product into operation. It is also absolutely essential to observe the additional safety instructions on personal safety that appear in relevant parts of the product documentation. In these safety instructions, the word "product" refers to all merchandise sold and distributed by the Rohde & Schwarz group of companies, including instruments, systems and all accessories.

## Tags and their meaning

DANGER	DANGER indicates a hazardous situation which, if not avoided, will result in death or serious injury.
WARNING	WARNING indicates a hazardous situation which, if not avoided, could result in death or serious injury.
CAUTION	CAUTION indicates a hazardous situation which, if not avoided, may result in minor or moderate injury.
NOTICE	NOTICE indicates a property damage message.

In the product documentation, the word ATTENTION is used synonymously.

These tags are in accordance with the standard definition for civil applications in the European Economic Area. Definitions that deviate from the standard definition may also exist in other economic areas or military applications. It is therefore essential to make sure that the tags described here are always used only in connection with the related product documentation and the related product. The use of tags in connection with unrelated products or documentation can result in misinterpretation and thus contribute to personal injury or material damage.

## Basic safety instructions

1. The product may be operated only under the operating conditions and in the positions specified by the manufacturer. Its ventilation must not be obstructed during operation. Unless otherwise specified, the following requirements apply to Rohde & Schwarz products:  
prescribed operating position is always with the housing floor facing down, IP protection 2X, pollution severity 2, overvoltage category 2, use only in enclosed spaces, max. operation altitude 2000 m above sea level, max. transport altitude 4500 m above sea level.  
A tolerance of  $\pm 10\%$  shall apply to the nominal voltage and of  $\pm 5\%$  to the nominal frequency.
2. Applicable local or national safety regulations and rules for the prevention of accidents must be observed in all work performed. The product may be opened only by authorized, specially trained personnel. Prior to performing any work on the product or opening the product, the product must be disconnected from the supply network. Any adjustments, replacements of parts, maintenance or repair must be carried out only by technical personnel authorized by Rohde & Schwarz. Only original parts may be used for replacing parts relevant to safety (e.g. power switches, power transformers, fuses). A safety test must always be performed after parts relevant to safety have been replaced (visual inspection, PE conductor test, insulation resistance measurement, leakage current measurement, functional test).
3. As with all industrially manufactured goods, the use of substances that induce an allergic reaction (allergens, e.g. nickel) such as aluminum cannot be generally excluded. If you develop an allergic reaction (such as a skin rash, frequent sneezing, red eyes or respiratory difficulties), consult a physician immediately to determine the cause.
4. If products/components are mechanically and/or thermally processed in a manner that goes beyond their intended use, hazardous substances (heavy-metal dust such as lead, beryllium, nickel) may be released. For this reason, the product may only be disassembled, e.g. for disposal purposes, by specially trained personnel. Improper disassembly may be hazardous to your health. National waste disposal regulations must be observed.



5. If handling the product yields hazardous substances or fuels that must be disposed of in a special way, e.g. coolants or engine oils that must be replenished regularly, the safety instructions of the manufacturer of the hazardous substances or fuels and the applicable regional waste disposal regulations must be observed. Also observe the relevant safety instructions in the product documentation.
6. Depending on the function, certain products such as RF radio equipment can produce an elevated level of electromagnetic radiation. Considering that unborn life requires increased protection, pregnant women should be protected by appropriate measures. Persons with pacemakers may also be endangered by electromagnetic radiation. The employer/operator is required to assess workplaces where there is a special risk of exposure to radiation and, if necessary, take measures to avert the danger.
7. Operating the products requires special training and intense concentration. Make certain that persons who use the products are physically, mentally and emotionally fit enough to handle operating the products; otherwise injuries or material damage may occur. It is the responsibility of the employer to select suitable personnel for operating the products.
8. Prior to switching on the product, it must be ensured that the nominal voltage setting on the product matches the nominal voltage of the AC supply network. If a different voltage is to be set, the power fuse of the product may have to be changed accordingly.
9. In the case of products of safety class I with movable power cord and connector, operation is permitted only on sockets with earthing contact and protective earth connection.
10. Intentionally breaking the protective earth connection either in the feed line or in the product itself is not permitted. Doing so can result in the danger of an electric shock from the product. If extension cords or connector strips are implemented, they must be checked on a regular basis to ensure that they are safe to use.
11. If the product has no power switch for disconnection from the AC supply, the plug of the connecting cable is regarded as the disconnecting device. In such cases, it must be ensured that the power plug is easily reachable and accessible at all times (corresponding to the length of connecting cable, approx. 2 m). Functional or electronic switches are not suitable for providing disconnection from the AC supply. If products without power switches are integrated in racks or systems, a disconnecting device must be provided at the system level.
12. Never use the product if the power cable is damaged. Check the power cable on a regular basis to ensure that it is in proper operating condition. By taking appropriate safety measures and carefully laying the power cable, ensure that the cable cannot be damaged and that no one can be hurt by e.g. tripping over the cable or suffering an electric shock.
13. The product may be operated only from TN/TT supply networks fused with max. 16 A (higher fuse only after consulting with the Rohde & Schwarz group of companies).
14. Do not insert the plug into sockets that are dusty or dirty. Insert the plug firmly and all the way into the socket. Otherwise, this can result in sparks, fire and/or injuries.
15. Do not overload any sockets, extension cords or connector strips; doing so can cause fire or electric shocks.
16. For measurements in circuits with voltages  $V_{\text{rms}} > 30 \text{ V}$ , suitable measures (e.g. appropriate measuring equipment, fusing, current limiting, electrical separation, insulation) should be taken to avoid any hazards.
17. Ensure that the connections with information technology equipment comply with IEC 950/EN 60950.
18. Unless expressly permitted, never remove the cover or any part of the housing while the product is in operation. Doing so will expose circuits and components and can lead to injuries, fire or damage to the product.
19. If a product is to be permanently installed, the connection between the PE terminal on site and the product's PE conductor must be made first before any other connection is made. The product may be installed and connected only by a license electrician.

20. For permanently installed equipment without built-in fuses, circuit breakers or similar protective devices, the supply circuit must be fused in such a way that suitable protection is provided for users and products.
21. Do not insert any objects into the openings in the housing that are not designed for this purpose. Never pour any liquids onto or into the housing. This can cause short circuits inside the product and/or electric shocks, fire or injuries.
22. Use suitable overvoltage protection to ensure that no overvoltage (such as that caused by a thunderstorm) can reach the product. Otherwise the operating personnel will be endangered by electric shocks.
23. Rohde & Schwarz products are not protected against penetration of liquids, unless otherwise specified (see also safety instruction 1.). If this is not taken into account, there exists the danger of electric shock for the user or damage to the product, which can also lead to personal injury.
24. Never use the product under conditions in which condensation has formed or can form in or on the product, e.g. if the product was moved from a cold to a warm environment.
25. Do not close any slots or openings on the product, since they are necessary for ventilation and prevent the product from overheating. Do not place the product on soft surfaces such as sofas or rugs or inside a closed housing, unless this is well ventilated.
26. Do not place the product on heat-generating devices such as radiators or fan heaters. The temperature of the environment must not exceed the maximum temperature specified in the data sheet.
27. Batteries and storage batteries must not be exposed to high temperatures or fire. Keep batteries and storage batteries away from children. Do not short-circuit batteries and storage batteries.  
If batteries or storage batteries are improperly replaced, this can cause an explosion (warning: lithium cells). Replace the battery or storage battery only with the matching Rohde & Schwarz type (see spare parts list). Batteries and storage batteries must be recycled and kept separate from residual waste. Batteries and storage batteries that contain lead, mercury or cadmium are hazardous waste. Observe the national regulations regarding waste disposal and recycling.
28. Please be aware that in the event of a fire, toxic substances (gases, liquids etc.) that may be hazardous to your health may escape from the product.
29. The product can be very heavy. Be careful when moving it to avoid back or other physical injuries.
30. Do not place the product on surfaces, vehicles, cabinets or tables that for reasons of weight or stability are unsuitable for this purpose. Always follow the manufacturer's installation instructions when installing the product and fastening it to objects or structures (e.g. walls and shelves).
31. Handles on the products are designed exclusively for personnel to hold or carry the product. It is therefore not permissible to use handles for fastening the product to or on means of transport such as cranes, fork lifts, wagons, etc. The user is responsible for securely fastening the products to or on the means of transport and for observing the safety regulations of the manufacturer of the means of transport. Noncompliance can result in personal injury or material damage.
32. If you use the product in a vehicle, it is the sole responsibility of the driver to drive the vehicle safely. Adequately secure the product in the vehicle to prevent injuries or other damage in the event of an accident. Never use the product in a moving vehicle if doing so could distract the driver of the vehicle. The driver is always responsible for the safety of the vehicle. The manufacturer assumes no responsibility for accidents or collisions.
33. If a laser product (e.g. a CD/DVD drive) is integrated in a Rohde & Schwarz product, do not use any other settings or functions than those described in the product documentation. Otherwise this may be hazardous to your health, since the laser beam can cause irreversible damage to your eyes. Never try to take such products apart, and never look into the laser beam.
34. Prior to cleaning, disconnect the product from the AC supply. Use a soft, non-linting cloth to clean the product. Never use chemical cleaning agents such as alcohol, acetone or diluent for cellulose lacquers.

# Informaciones elementales de seguridad

**¡Es imprescindible leer y observar las siguientes instrucciones e informaciones de seguridad!**







El principio del grupo de empresas Rohde & Schwarz consiste en tener nuestros productos siempre al día con los estándares de seguridad y de ofrecer a nuestros clientes el máximo grado de seguridad. Nuestros productos y todos los equipos adicionales son siempre fabricados y examinados según las normas de seguridad vigentes. Nuestra sección de gestión de la seguridad de calidad controla constantemente que sean cumplidas estas normas. El presente producto ha sido fabricado y examinado según el comprobante de conformidad adjunto según las normas de la CE y ha salido de nuestra planta en estado impecable según los estándares técnicos de seguridad. Para poder preservar este estado y garantizar un funcionamiento libre de peligros, el usuario deberá atenerse a todas las indicaciones, informaciones de seguridad y notas de alerta. El grupo de empresas Rohde & Schwarz está siempre a su disposición en caso de que tengan preguntas referentes a estas informaciones de seguridad.

Además queda en la responsabilidad del usuario utilizar el producto en la forma debida. Este producto está destinado exclusivamente al uso en la industria y el laboratorio o, si ha sido expresamente autorizado, para aplicaciones de campo y de ninguna manera deberá ser utilizado de modo que alguna persona/cosa pueda sufrir daño. El uso del producto fuera de sus fines definidos o despreciando las informaciones de seguridad del fabricante queda en la responsabilidad del usuario. El fabricante no se hace en ninguna forma responsable de consecuencias a causa del mal uso del producto.

Se parte del uso correcto del producto para los fines definidos si el producto es utilizado dentro de las instrucciones de la correspondiente documentación de producto y dentro del margen de rendimiento definido (ver hoja de datos, documentación, informaciones de seguridad que siguen). El uso del producto hace necesarios conocimientos profundos y conocimientos básicas del idioma inglés. Por eso se debe tener en cuenta que el producto sólo pueda ser operado por personal especializado o personas minuciosamente instruidas con las capacidades correspondientes. Si fuera necesaria indumentaria de seguridad para el uso de productos de R&S, encontrará la información debida en la documentación del producto en el capítulo correspondiente. Guarde bien las informaciones de seguridad elementales, así como la documentación del producto y entréguela a usuarios posteriores.

## Símbolos y definiciones de seguridad

							
Ver documentación de producto	Informaciones para maquinaria con un peso de > 18kg	Peligro de golpe de corriente	¡Advertencia! Superficie caliente	Conexión a conductor protector	Conexión a tierra	Conexión a masa conductora	¡Cuidado! Elementos de construcción con peligro de carga electrostática

					
Potencia EN MARCHA/PARADA	Indicación Stand-by	Corriente continua DC	Corriente alterna AC	Corriente continua/- alterna DC/AC	El aparato está protegido en su totalidad por un aislamiento de doble refuerzo

Tener en cuenta las informaciones de seguridad sirve para tratar de evitar daños y peligros de toda clase. Es necesario de que se lean las siguientes informaciones de seguridad concienzudamente y se tengan en cuenta debidamente antes de la puesta en funcionamiento del producto. También deberán ser tenidas en cuenta las informaciones para la protección de personas que encontrarán en el capítulo correspondiente de la documentación de producto y que también son obligatorias de seguir. En las informaciones de seguridad actuales hemos juntado todos los objetos vendidos por el grupo de empresas Rohde & Schwarz bajo la denominación de „producto“, entre ellos también aparatos, instalaciones así como toda clase de accesorios.

### Palabras de señal y su significado

PELIGRO	Identifica un peligro directo con riesgo elevado de provocar muerte o lesiones de gravedad si no se toman las medidas oportunas.
ADVERTENCIA	Identifica un posible peligro con riesgo medio de provocar muerte o lesiones (de gravedad) si no se toman las medidas oportunas.
ATENCIÓN	Identifica un peligro con riesgo reducido de provocar lesiones de gravedad media o leve si no se toman las medidas oportunas.
AVISO	Indica la posibilidad de utilizar mal el producto y a consecuencia dañarlo.

En la documentación del producto se emplea de forma sinónima el término CUIDADO.

Las palabras de señal corresponden a la definición habitual para aplicaciones civiles en el área económica europea. Pueden existir definiciones diferentes a esta definición en otras áreas económicas o en aplicaciones militares. Por eso se deberá tener en cuenta que las palabras de señal aquí descritas sean utilizadas siempre solamente en combinación con la correspondiente documentación de producto y solamente en combinación con el producto correspondiente. La utilización de las palabras de señal en combinación con productos o documentaciones que no les correspondan puede llevar a malinterpretaciones y tener por consecuencia daños en personas u objetos.

### Informaciones de seguridad elementales

1. El producto solamente debe ser utilizado según lo indicado por el fabricante referente a la situación y posición de funcionamiento sin que se obstruya la ventilación. Si no se convino de otra manera, es para los productos R&S válido lo que sigue:  
como posición de funcionamiento se define por principio la posición con el suelo de la caja para abajo, modo de protección IP 2X, grado de suciedad 2, categoría de sobrecarga eléctrica 2, utilizar solamente en estancias interiores, utilización hasta 2000 m sobre el nivel del mar, transporte hasta 4.500 m sobre el nivel del mar.  
Se aplicará una tolerancia de  $\pm 10\%$  sobre el voltaje nominal y de  $\pm 5\%$  sobre la frecuencia nominal.
2. En todos los trabajos deberán ser tenidas en cuenta las normas locales de seguridad de trabajo y de prevención de accidentes. El producto solamente debe de ser abierto por personal especializado autorizado. Antes de efectuar trabajos en el producto o abrirlo deberá este ser desconectado de la corriente. El ajuste, el cambio de partes, la manutención y la reparación deberán ser solamente efectuadas por electricistas autorizados por R&S. Si se reponen partes con importancia para los aspectos de seguridad (por ejemplo el enchufe, los transformadores o los fusibles), solamente podrán ser sustituidos por partes originales. Después de cada recambio de partes elementales para la seguridad deberá ser efectuado un control de seguridad (control a primera vista, control de conductor protector, medición de resistencia de aislamiento, medición de la corriente conductora, control de funcionamiento).

3. Como en todo producto de fabricación industrial no puede ser excluido en general de que se produzcan al usarlo elementos que puedan generar alergias, los llamados elementos alergénicos (por ejemplo el níquel). Si se produjeran en el trato con productos R&S reacciones alérgicas, como por ejemplo urticaria, estornudos frecuentes, irritación de la conjuntiva o dificultades al respirar, se deberá consultar inmediatamente a un médico para averiguar los motivos de estas reacciones.
  4. Si productos / elementos de construcción son tratados fuera del funcionamiento definido de forma mecánica o térmica, pueden generarse elementos peligrosos (polvos de sustancia de metales pesados como por ejemplo plomo, berilio, níquel). La partición elemental del producto, como por ejemplo sucede en el tratamiento de materias residuales, debe de ser efectuada solamente por personal especializado para estos tratamientos. La partición elemental efectuada inadecuadamente puede generar daños para la salud. Se deben tener en cuenta las directivas nacionales referentes al tratamiento de materias residuales.
  5. En el caso de que se produjeran agentes de peligro o combustibles en la aplicación del producto que debieran de ser transferidos a un tratamiento de materias residuales, como por ejemplo agentes refrigerantes que deben ser repuestos en periodos definidos, o aceites para motores, deberán ser tenidas en cuenta las prescripciones de seguridad del fabricante de estos agentes de peligro o combustibles y las regulaciones regionales para el tratamiento de materias residuales. Cuiden también de tener en cuenta en caso dado las prescripciones de seguridad especiales en la descripción del producto.
  6. Ciertos productos, como por ejemplo las instalaciones de radiocomunicación RF, pueden a causa de su función natural, emitir una radiación electromagnética aumentada. En vista a la protección de la vida en desarrollo deberían ser protegidas personas embarazadas debidamente. También las personas con un bypass pueden correr peligro a causa de la radiación electromagnética.
- El empresario/usuario está comprometido a valorar y señalar áreas de trabajo en las que se corra un riesgo aumentado de exposición a radiaciones para evitar riesgos.
7. La utilización de los productos requiere instrucciones especiales y una alta concentración en el manejo. Debe de ponerse por seguro de que las personas que manejen los productos estén a la altura de los requerimientos necesarios referente a sus aptitudes físicas, psíquicas y emocionales, ya que de otra manera no se pueden excluir lesiones o daños de objetos. El empresario lleva la responsabilidad de seleccionar el personal usuario apto para el manejo de los productos.
  8. Antes de la puesta en marcha del producto se deberá tener por seguro de que la tensión preseleccionada en el producto equivalga a la del la red de distribución. Si es necesario cambiar la preselección de la tensión también se deberán en caso dabo cambiar los fusibles correspondientes del producto.
  9. Productos de la clase de seguridad I con alimentación móvil y enchufe individual de producto solamente deberán ser conectados para el funcionamiento a tomas de corriente de contacto de seguridad y con conductor protector conectado.
  10. Queda prohibida toda clase de interrupción intencionada del conductor protector, tanto en la toma de corriente como en el mismo producto. Puede tener como consecuencia el peligro de golpe de corriente por el producto. Si se utilizaran cables o enchufes de extensión se deberá poner al seguro que es controlado su estado técnico de seguridad.
  11. Si el producto no está equipado con un interruptor para desconectarlo de la red, se deberá considerar el enchufe del cable de distribución como interruptor. En estos casos deberá asegurar de que el enchufe sea de fácil acceso y nabejo (según la medida del cable de distribución, aproximadamente 2 m). Los interruptores de función o electrónicos no son aptos para el corte de la red eléctrica. Si los productos sin interruptor están integrados en bastidores o instalaciones, se deberá instalar el interruptor al nivel de la instalación.

12. No utilice nunca el producto si está dañado el cable eléctrico. Compruebe regularmente el correcto estado de los cables de conexión a red. Asegure a través de las medidas de protección y de instalación adecuadas de que el cable de eléctrico no pueda ser dañado o de que nadie pueda ser dañado por él, por ejemplo al tropezar o por un golpe de corriente.
13. Solamente está permitido el funcionamiento en redes de distribución TN/TT aseguradas con fusibles de como máximo 16 A (utilización de fusibles de mayor amperaje sólo previa consulta con el grupo de empresas Rohde & Schwarz).
14. Nunca conecte el enchufe en tomas de corriente sucias o llenas de polvo. Introduzca el enchufe por completo y fuertemente en la toma de corriente. Si no tiene en consideración estas indicaciones se arriesga a que se originen chispas, fuego y/o heridas.
15. No sobrecargue las tomas de corriente, los cables de extensión o los enchufes de extensión ya que esto pudiera causar fuego o golpes de corriente.
16. En las mediciones en circuitos de corriente con una tensión de entrada de  $U_{eff} > 30$  V se deberá tomar las precauciones debidas para impedir cualquier peligro (por ejemplo medios de medición adecuados, seguros, limitación de tensión, corte protector, aislamiento etc.).
17. En caso de conexión con aparatos de la técnica informática se deberá tener en cuenta que estos cumplan los requisitos del estándar IEC950/EN60950.
18. A menos que esté permitido expresamente, no retire nunca la tapa ni componentes de la carcasa mientras el producto esté en servicio. Esto pone a descubierto los cables y componentes eléctricos y puede causar heridas, fuego o daños en el producto.
19. Si un producto es instalado fijamente en un lugar, se deberá primero conectar el conductor protector fijo con el conductor protector del aparato antes de hacer cualquier otra conexión. La instalación y la conexión deberán ser efectuadas por un electricista especializado.
20. En caso de que los productos que son instalados fijamente en un lugar sean sin protector implementado, autointerruptor o similares objetos de protección, el circuito de suministro de corriente deberá estar protegido de manera que usuarios y productos estén suficientemente protegidos.
21. Por favor, no introduzca ningún objeto que no esté destinado a ello en los orificios de la caja del aparato. No vierta nunca ninguna clase de líquidos sobre o en la caja. Esto puede producir cortocircuitos en el producto y/o puede causar golpes de corriente, fuego o heridas.
22. Asegúrese con la protección adecuada de que no pueda originarse en el producto una sobrecarga por ejemplo a causa de una tormenta. Si no se verá el personal que lo utilice expuesto al peligro de un golpe de corriente.
23. Los productos R&S no están protegidos contra líquidos si no es que exista otra indicación, ver también punto 1. Si no se tiene en cuenta esto se arriesga el peligro de golpe de corriente para el usuario o de daños en el producto lo cual también puede llevar al peligro de personas.
24. No utilice el producto bajo condiciones en las que pueda producirse y se hayan producido líquidos de condensación en o dentro del producto como por ejemplo cuando se desplaza el producto de un lugar frío a un lugar caliente.
25. Por favor no cierre ninguna ranura u orificio del producto, ya que estas son necesarias para la ventilación e impiden que el producto se caliente demasiado. No pongan el producto encima de materiales blandos como por ejemplo sofás o alfombras o dentro de una caja cerrada, si esta no está suficientemente ventilada.
26. No ponga el producto sobre aparatos que produzcan calor, como por ejemplo radiadores o calentadores. La temperatura ambiental no debe superar la temperatura máxima especificada en la hoja de datos.

27. Baterías y acumuladores no deben de ser expuestos a temperaturas altas o al fuego. Guardar baterías y acumuladores fuera del alcance de los niños. No cortocircuitar baterías ni acumuladores. Si las baterías o los acumuladores no son cambiados con la debida atención existirá peligro de explosión (atención células de litio). Cambiar las baterías o los acumuladores solamente por los del tipo R&S correspondiente (ver lista de piezas de recambio). Las baterías y acumuladores deben reutilizarse y no deben acceder a los vertederos. Las baterías y acumuladores que contienen plomo, mercurio o cadmio deben tratarse como residuos especiales. Respete en esta relación las normas nacionales de evacuación y reciclaje.
28. Por favor tengan en cuenta que en caso de un incendio pueden desprenderse del producto agentes venenosos (gases, líquidos etc.) que pueden generar daños a la salud.
29. El producto puede poseer un peso elevado. Muévelo con cuidado para evitar lesiones en la espalda u otras partes corporales.
30. No sitúe el producto encima de superficies, vehículos, estantes o mesas, que por sus características de peso o de estabilidad no sean aptas para él. Siga siempre las instrucciones de instalación del fabricante cuando instale y asegure el producto en objetos o estructuras (por ejemplo paredes y estantes).
31. Las asas instaladas en los productos sirven solamente de ayuda para el manejo que solamente está previsto para personas. Por eso no está permitido utilizar las asas para la sujeción en o sobre medios de transporte como por ejemplo grúas, carretillas elevadoras de horquilla, carros etc. El usuario es responsable de que los productos sean sujetados de forma segura a los medios de transporte y de que las prescripciones de seguridad del fabricante de los medios de transporte sean observadas. En caso de que no se tengan en cuenta pueden causarse daños en personas y objetos.
32. Si llega a utilizar el producto dentro de un vehículo, queda en la responsabilidad absoluta del conductor que conducir el vehículo de manera segura. Asegure el producto dentro del vehículo debidamente para evitar en caso de un accidente las lesiones u otra clase de daños. No utilice nunca el producto dentro de un vehículo en movimiento si esto pudiera distraer al conductor. Siempre queda en la responsabilidad absoluta del conductor la seguridad del vehículo. El fabricante no asumirá ninguna clase de responsabilidad por accidentes o colisiones.
33. Dado el caso de que esté integrado un producto de láser en un producto R&S (por ejemplo CD/DVD-ROM) no utilice otras instalaciones o funciones que las descritas en la documentación de producto. De otra manera pondrá en peligro su salud, ya que el rayo láser puede dañar irreversiblemente sus ojos. Nunca trate de descomponer estos productos. Nunca mire dentro del rayo láser.
34. Antes de proceder a la limpieza, desconecte el producto de la red. Realice la limpieza con un paño suave, que no se deshilache. No utilice de ninguna manera agentes limpiadores químicos como, por ejemplo, alcohol, acetona o nitrodiluyente.

## Safety Instructions

### WARNING



*Danger of injuries*

*When removing the rear feet, the unit can slip out of the cabinet.*

*Put the unit onto the front handles, before removing the rear feet and taking off the cabinet. Thus the risk of personal injuries and damages to the unit is avoided.*

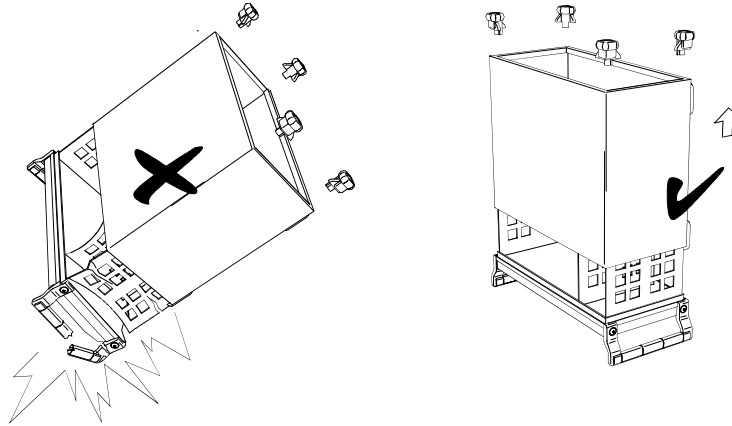

*When mounting the cabinet take care not to pen in the fingers. Also pay attention not to damage or pull off cables. Screw the rear feet back on immediately after mounting the cabinet. Do not move the unit with the rear feet missing.*

### ATTENTION



*To avoid damage of electronic components, the operational site must be protected against electrostatic discharge (ESD).*

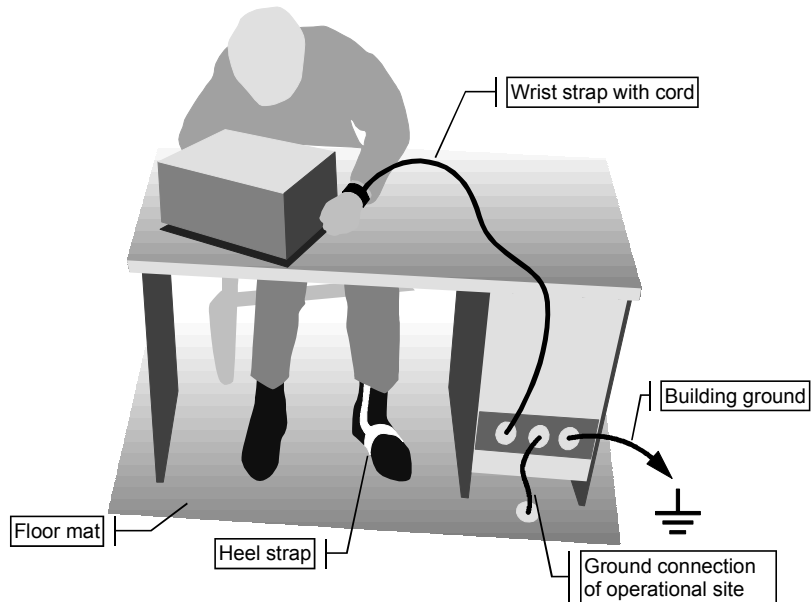

*The following two methods of ESD protection may be used together or separately:*

- *Wrist strap with cord to ground connection*
- *Conductive floor mat and heel strap combination*



## Customer Information Regarding Product Disposal

The German Electrical and Electronic Equipment (ElektroG) Act is an implementation of the following EC directives:

- 2002/96/EC on waste electrical and electronic equipment (WEEE) and
- 2002/95/EC on the restriction of the use of certain hazardous substances in electrical and electronic equipment (RoHS).



Product labeling in accordance with EN 50419

Once the lifetime of a product has ended, this product must not be disposed of in the standard domestic refuse. Even disposal via the municipal collection points for waste electrical and electronic equipment is not permitted.

Rohde & Schwarz GmbH & Co. KG has developed a disposal concept for the environmental-friendly disposal or recycling of waste material and fully assumes its obligation as a producer to take back and dispose of electrical and electronic waste in accordance with the ElektroG Act.

Please contact your local service representative to dispose of the product.



## Certified Quality System

**DIN EN ISO 9001 : 2000**  
**DIN EN 9100 : 2003**  
**DIN EN ISO 14001 : 2004**

**DQS REG. NO 001954 QM UM**

### QUALITÄTSZERTIFIKAT

*Sehr geehrter Kunde,*

Sie haben sich für den Kauf eines Rohde & Schwarz-Produktes entschieden. Hiermit erhalten Sie ein nach modernsten Fertigungsmethoden hergestelltes Produkt. Es wurde nach den Regeln unseres Managementsystems entwickelt, gefertigt und geprüft.

Das Rohde & Schwarz Managementsystem ist zertifiziert nach:

DIN EN ISO 9001:2000  
DIN EN 9100:2003  
DIN EN ISO 14001:2004

### CERTIFICATE OF QUALITY

*Dear Customer,*

you have decided to buy a Rohde & Schwarz product. You are thus assured of receiving a product that is manufactured using the most modern methods available. This product was developed, manufactured and tested in compliance with our quality management system standards.

The Rohde & Schwarz quality management system is certified according to:

DIN EN ISO 9001:2000  
DIN EN 9100:2003  
DIN EN ISO 14001:2004

### CERTIFICAT DE QUALITÉ

*Cher Client,*

vous avez choisi d'acheter un produit Rohde & Schwarz. Vous disposez donc d'un produit fabriqué d'après les méthodes les plus avancées. Le développement, la fabrication et les tests respectent nos normes de gestion qualité.

Le système de gestion qualité de Rohde & Schwarz a été homologué conformément aux normes:

DIN EN ISO 9001:2000  
DIN EN 9100:2003  
DIN EN ISO 14001:2004



**ROHDE & SCHWARZ**



# Customer Support

## Technical support – where and when you need it

For quick, expert help with any Rohde & Schwarz equipment, contact one of our Customer Support Centers. A team of highly qualified engineers provides telephone support and will work with you to find a solution to your query on any aspect of the operation, programming or applications of Rohde & Schwarz equipment.

## Up-to-date information and upgrades

To keep your instrument up-to-date and to be informed about new application notes related to your instrument, please send an e-mail to the Customer Support Center stating your instrument and your wish.

We will take care that you will get the right information.

### USA & Canada

Monday to Friday (except US public holidays)

8:00 AM – 8:00 PM Eastern Standard Time (EST)

Tel. from USA 888-test-rsa (888-837-8772) (opt 2)

From outside USA +1 410 910 7800 (opt 2)

Fax +1 410 910 7801

E-mail [CustomerSupport@rohde-schwarz.com](mailto:CustomerSupport@rohde-schwarz.com)

### East Asia

Monday to Friday (except Singaporean public holidays)

8:30 AM – 6:00 PM Singapore Time (SGT)

Tel. +65 6 513 0488

Fax +65 6 846 1090

E-mail [CustomerSupport@rohde-schwarz.com](mailto:CustomerSupport@rohde-schwarz.com)

### Rest of the World

Monday to Friday (except German public holidays)

08:00 – 17:00 Central European Time (CET)

Tel. from Europe +49 (0) 180 512 42 42\*

From outside Europe +49 89 4129 13776

Fax +49 (0) 89 41 29 637 78

E-mail [CustomerSupport@rohde-schwarz.com](mailto:CustomerSupport@rohde-schwarz.com)

\* 0.14 €/Min within the German fixed-line telephone network, varying prices for the mobile telephone network and in different countries.





## Address List

### Headquarters, Plants and Subsidiaries

#### Headquarters

ROHDE & SCHWARZ GmbH & Co. KG  
Mühlendorfstraße 15 · D-81671 München  
P.O.Box 80 14 69 · D-81614 München

Phone +49 (89) 41 29-0  
Fax +49 (89) 41 29-121 64  
[info.rs@rohde-schwarz.com](mailto:info.rs@rohde-schwarz.com)

#### Plants

ROHDE & SCHWARZ Messgerätebau GmbH  
Riedbachstraße 58 · D-87700 Memmingen  
P.O.Box 16 52 · D-87686 Memmingen

Phone +49 (83 31) 1 08-0  
+49 (83 31) 1 08-1124  
[info.rsmb@rohde-schwarz.com](mailto:info.rsmb@rohde-schwarz.com)

ROHDE & SCHWARZ GmbH & Co. KG  
Werk Teisnach  
Kaikenrieder Straße 27 · D-94244 Teisnach  
P.O.Box 11 49 · D-94240 Teisnach

Phone +49 (99 23) 8 50-0  
Fax +49 (99 23) 8 50-174  
[info.rsdt@rohde-schwarz.com](mailto:info.rsdt@rohde-schwarz.com)

ROHDE & SCHWARZ závod  
Vimperk, s.r.o.  
Location Spidrova 49  
CZ-38501 Vimperk

Phone +420 (388) 45 21 09  
Fax +420 (388) 45 21 13

ROHDE & SCHWARZ GmbH & Co. KG  
Dienstleistungszentrum Köln  
Graf-Zeppelin-Straße 18 · D-51147 Köln  
P.O.Box 98 02 60 · D-51130 Köln

Phone +49 (22 03) 49-0  
Fax +49 (22 03) 49 51-229  
[info.rsdc@rohde-schwarz.com](mailto:info.rsdc@rohde-schwarz.com)  
[service.rsdc@rohde-schwarz.com](mailto:service.rsdc@rohde-schwarz.com)

#### Subsidiaries

R&S BICK Mobilfunk GmbH  
Fritz-Hahne-Str. 7 · D-31848 Bad Münder  
P.O.Box 20 02 · D-31844 Bad Münder

Phone +49 (50 42) 9 98-0  
Fax +49 (50 42) 9 98-105  
[info.bick@rohde-schwarz.com](mailto:info.bick@rohde-schwarz.com)

ROHDE & SCHWARZ FTK GmbH  
Wendenschloßstraße 168, Haus 28  
D-12557 Berlin

Phone +49 (30) 658 91-122  
Fax +49 (30) 655 50-221  
[info.ftk@rohde-schwarz.com](mailto:info.ftk@rohde-schwarz.com)

ROHDE & SCHWARZ SIT GmbH  
Am Studio 3  
D-12489 Berlin

Phone +49 (30) 658 84-0  
Fax +49 (30) 658 84-183  
[info.sit@rohde-schwarz.com](mailto:info.sit@rohde-schwarz.com)

R&S Systems GmbH  
Graf-Zeppelin-Straße 18  
D-51147 Köln

Phone +49 (22 03) 49-5 23 25  
Fax +49 (22 03) 49-5 23 36  
[info.rssys@rohde-schwarz.com](mailto:info.rssys@rohde-schwarz.com)

GEDIS GmbH  
Sophienblatt 100  
D-24114 Kiel

Phone +49 (431) 600 51-0  
Fax +49 (431) 600 51-11  
[sales@gedis-online.de](mailto:sales@gedis-online.de)

HAMEG Instruments GmbH  
Industriestraße 6  
D-63533 Mainhausen

Phone +49 (61 82) 800-0  
Fax +49 (61 82) 800-100  
[info@hameg.de](mailto:info@hameg.de)

### Locations Worldwide

Please refer to our homepage: [www.rohde-schwarz.com](http://www.rohde-schwarz.com)

- ◆ Sales Locations
- ◆ Service Locations
- ◆ National Websites





# Procedure in Case of Service and Ordering of Spare Parts

This section contains information on shipping an instrument to your service center and ordering spare parts.

## Shipping of Instrument

Please contact your local Rohde & Schwarz service center if you need service or repair work of your equipment or wish to order spare parts. The list of the Rohde & Schwarz representatives is provided at the beginning of this manual. You can find the current address of your representative on our homepage [www.rohde-schwarz.com](http://www.rohde-schwarz.com). Navigate to Service & Support / Service Locations.

We require the following information in order to answer your inquiry fast and correctly:

- Instrument type designation
- Instrument stock number
- Instrument serial number
- Firmware version
- Indication whether the instrument should be updated to the latest firmware version during service or the existing firmware retained
- Detailed error description in case of repair
- Indication of desired calibration
- Contact person for possible questions

In some countries, an RMA process is available for the return shipment of the instrument. The RMA process allows faster and more efficient repair of your instrument at no additional cost. The progress of repair may be viewed at all times, and the transport costs are already included. For details, contact your local representative.

- When shipping the instrument, be careful to provide for sufficient mechanical and antistatic protection. Use the original packaging for transporting or shipping the instrument. The protective caps for the front and rear prevent damage to the operating elements and the connectors.
- If you do not use the original packaging, provide for sufficient padding to prevent the instrument from slipping inside the box. Wrap antistatic packing foil around the instrument to protect it from electrostatic charging.

Rohde & Schwarz offers repair and calibration of the test systems it produces. The calibration documentation fulfills ISO 17025 requirements.

## Ordering Spare Parts

Please contact your local Rohde & Schwarz service center if you need service or repair work of your equipment or wish to order spare parts. The list of the Rohde & Schwarz representatives is provided at the beginning of this manual. You can find the current address of your representative on our homepage [www.rohde-schwarz.com](http://www.rohde-schwarz.com). Navigate to Service & Support / Service Locations.

To deliver spare parts promptly and correctly, we need the following information:

- Stock number (see list of spare parts in chapter “Documents”)
- Designation
- Component number as indicated in list of spare parts
- Number of pieces
- Instrument type for which the spare part is needed
- Instrument stock number
- Instrument serial number
- Contact person for possible questions

## Shipping Defective Modules

Also when shipping a module, be careful to provide for sufficient mechanical and antistatic protection.

- Ship the module in a sturdy, padded box.
- Wrap the module in antistatic foil.

If the packaging is only antistatic but not conductive, additional conductive packaging is required. Additional packaging is not required if the tightly fitting packaging is conductive.

**Exception:**

*If the module contains a battery, the tightly fitting packaging must always consist of antistatic, non-chargeable material to protect the battery from being discharged.*

## Refurbished Modules

Refurbished modules are an economical alternative to original modules. Bear in mind that refurbished modules are not new, but repaired and fully tested parts. They may show traces from use, but they are electrically and mechanically equivalent to new modules.

Your Rohde & Schwarz representative will be happy to inform you about which modules are available as refurbished modules.

## Taking Back Defective Replaced Modules

Defective replaced modules that cannot be repaired are taken back within three months following delivery. A repurchasing value is credited.

Parts that cannot be repaired are excluded, e.g. printed boards that are burnt, broken or damaged by attempts to repair them, incomplete modules, and parts with severe mechanical damage.

Please return the defective replacement modules, together with the accompanying document for returned merchandise, which you received with the spare module. We need the following information:

- Stock number, serial number and designation of the removed part
- Detailed error description
- Stock number, serial number and type of instrument from which the module was removed
- Date of removal
- Name of the engineer/technician who replaced the module
- Rohde & Schwarz customer order number (is indicated on the accompanying document for returned merchandise)
- Service reference number (if available)



## Contents of User Documentation for the Signal Generator R&S SMC100A

The user documentation describes the Signal Generator R&S SMC and all options. It includes a printed Quick Start Guide and a CD-ROM with the complete operating and service manual in printable pdf-format and the data sheet.

The R&S SMC is equipped with a context-sensitive online help that offers a help page for each instrument function.

### Quick Start Guide

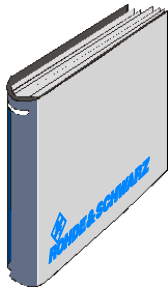

The present quick start guide describes everything that is needed to put the instrument into operation and to get familiar with the generator. The quick start guide gives an introduction to remote control and manual control via external monitor, mouse and keyboard.

The quick start guide is subdivided into 4 chapters plus index:

- Chapter 1** describes the control elements and connectors on the front and rear panel as well as all procedures required for putting the instrument into operation.
- Chapter 2** gives an introduction the operating concept and typical applications of the R&S SMC.
- Chapter 3** describes key operating modes, the structure of the graphical interface and the principles of manual control.
- Annex** contains an index for the quick start guide.

### Help System

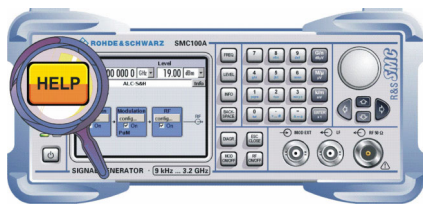

The help system is embedded in the instrument, offering quick, context-sensitive reference to the information needed for operation and programming. The help contains the complete user documentation for the Signal Generator including the contents of the present quick start guide.

The help files (\*.chm) are also available on the CD-ROM and can be used as a standalone help.

## Documentation CD-ROM

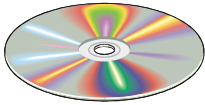

The CD-ROM provides the complete user documentation for the Signal Generator:

- The online help system (\*.chm).
- The complete operating manual and service manual in printable form (\*.pdf).
- The **data sheet** (brochure and data sheet) in printable form.
- Links to different useful sites in the R&S internet.

---

**Note:** Please use the ADOBE® Acrobat® Reader for PDF files and the browser Internet Explorer® ≥ 4.0 for the HTML help.

---

## Optional Documentation

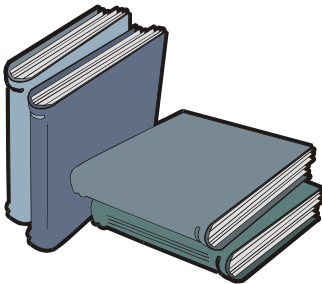

The printed version of the operating and service manual provides the contents of the quick start manual plus the complete reference and the service information for the Signal Generator. This manual can be ordered as an option (stock no. 1411.4060.32 (English - A4 format) or 1411.4060.39 (English - letter format )); see ordering information in the data sheet.

---

**Note:** The CD-ROM contains the \*.pdf version of the manuals.

---

## Manual Control

The operating manual contains comprehensive information about the instrument functions and remote control, in addition to the chapters of the quick start guide. It includes information about maintenance of the instrument and about error detection listing the error messages which may be output by the instrument. It is subdivided into 10 chapters:

- |                       |   |
|-----------------------|---|
| <b>The data sheet</b> | informs about specifications and characteristics of the instrument.   |
| <b>Chapter 1</b>      | describes the control elements and connectors on the front and rear panel as well as all procedures required for putting the instrument into operation. |
| <b>Chapter 2</b>      | gives an introduction to the operating concept and typical applications of the R&S SMC.   |
| <b>Chapter 3</b>      | describes key operating modes, the structure of the graphical interface and the principles of manual control.   |

**Chapter 4** forms a reference for manual control of the R&S SMC and contains a detailed description of all instrument functions and their application. The chapter also lists the remote control command corresponding to each instrument function.

## Remote Control

**Chapter 5** describes the basics for programming the R&S SMC, command processing and the status reporting system.

**Chapter 6** lists all the remote-control commands defined for the instrument.

**Chapter 7** -

**Chapter 8** describes preventive maintenance and the characteristics of the instrument's interfaces.

**Chapter 9** gives the status messages and a list of error messages that the R&S SMC may generate.

**Annex** lists the remote-control commands in alphabetical order, and contains an index of the operating manual.

## Service Manual Instrument

The service manual - instrument informs on how to check compliance with rated specifications, on instrument function, repair, troubleshooting and fault elimination. It contains all information required for the maintenance of R&S SMC by exchanging modules. In addition it describes how to perform a firmware update and how to install options.

## Internet Site

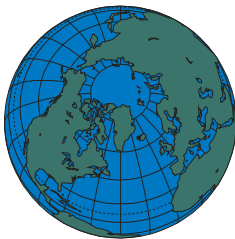

The Internet site at: [Signal Generator R&S SMC100A](#) provides the most up to date information on the R&S SMC. Additionally firmware updates including the associated release notes, instrument drivers, current data sheets and application notes are provided for download on the internet site.

The current operating manual at a time is available as printable PDF file in the download area.

## Contents - Chapter 1 "Performance Test"

<b>1 Checking the Rated Characteristics .....</b>	<b>1.1</b>
<b>Measuring Equipment and Accessories .....</b>	<b>1.1</b>
<b>Test Assemblies .....</b>	<b>1.2</b>
Standard Test Assembly for Analog Modulations .....	1.2
Test Assembly for Pulse Modulation .....	1.3
Test Assembly for Residual AM .....	1.3
Test Assembly for SSB Phase Noise and Jitter .....	1.4
Test Assembly for Output Impedance (VSWR) .....	1.4
Test Assembly for Setting Time .....	1.5
<b>Preparation, Recommended Test Frequencies and Levels .....</b>	<b>1.6</b>
<b>Test Procedures .....</b>	<b>1.7</b>
Reference Frequency .....	1.7
Frequency .....	1.8
Spectral Purity .....	1.11
Internal Modulation Generator .....	1.22
Amplitude Modulation .....	1.24
Frequency Modulation .....	1.29
Phase Modulation .....	1.33
Pulse Modulation .....	1.36
Pulse Generator .....	1.38





# 1 Checking the Rated Characteristics

This performance test describes the steps for testing the R&S SMC Signal Generator family and the installed options with respect to function and compliance with specifications.

In the following, the term DUT (Device under Test) is used for any signal generator of this family. The tests to be performed depend on the installed options. The values are given in the data sheet of the respective instrument.

## Measuring Equipment and Accessories

Table 1-1 Measuring equipment and accessories

Item	Type of Instrument	Required Characteristics	Suitable Instrument	R&S Order No.
1	Frequency counter	1 Hz to $RF_{max}$ , resolution 0.1 Hz (included in spectrum analyzer item 18)		
2	Reference source for SSB noise measurements	Identical generator as DUT or generator with at least 10 dB lower SSB noise as DUT Frequency range up to $RF_{max}$	R&S SMC100A with suited frequency option R&S SMB100A with suited frequency option Reference Synthesizer or R&S SMA100A with option R&S SMA-B106 or R&S SMU200A with option R&S SMU-B106	1411.4002.02 1406.6000.02 1158.2878 1400.0000.02 1405.0809.02 1142.2005.02 1141.8803.02
5	Signal generator	0.1 MHz to $RF_{max}$	R&S SMB with option R&S SMB-B106 R&S SMU with options R&S SMU-B106, -B10, -B31 or R&S SMA100A with option R&S SMA-B106	1406.6000.02 1407.2909.02 1141.2005.02 1400.0000.02 1405.0809.02
6	Phase noise test assembly	Phase Noise Test Set or Mixer: 10 MHz to $RF_{max}$ , branching filter 20 MHz, DC decoupling after the mixer	R&S FSUP 8 or FSU or FSQ with phase noise measurement option Mixer: f < 1 GHz: Minicircuits ZFM2H 1 GHz < f < 6 GHz: Miteq DB0118LA2	1166.3506.08
7	Oscilloscope	Bandwidth $\geq$ 100 MHz, two channels with DC coupling	<b>Tektronix TDS 1012B or similar</b>	
8	RF power meter	9 kHz to $RF_{max}$	R&S NRP with R&S NRP-Z91 R&S NRP-Z51 or R&S NRVS with R&S NRV-Z5 R&S NRV-Z51	1143.8500.02 1168.8004.02 1138.0005.02 1020.1809.02 0828.3818.02 0857.9004.02
9	Low-noise preamplifier	9 kHz to 1 MHz gain > 20 dB, input noise < 4 nV (1 Hz)	based an ADI AD829	
10	VSWR bridge	100 MHz to $RF_{max}$ directivity > 30 dB	R&S ZRC or Agilent 773D	1039.9492.55
12	RF power amplifier	10 MHz to $RF_{max}$ , power > 33 dBm	Mini Circuits ZHL-03-5WF	

Item	Type of Instrument	Required Characteristics	Suitable Instrument	R&S Order No.
13	Pulse generator	Pulse repetition frequency at least 10 kHz	R&S SMC100A or R&S SMB100A equipped with option K23 or R&S SMA100A	
14	AC/DC voltmeter	10 Hz to 100 kHz	R&S URE3	350.5315.03
15	Broadband FM demodulator	included in spectrum analyzer item 18		
16	RF attenuator	DC to RF <sub>max</sub> , 10 dB, system N	R&S DNF	0272.4210.50
17	RF attenuator	DC to RF <sub>max</sub> , 3 dB, system N	R&S DNF	0272.4010.50
18	RF analyzer & Demodulator for analog modulations & FM-demodulator	9 kHz to RF <sub>max</sub> * 3	R&S FSMR26 with options R&S FSU-B25 R&S FS-B223 or  R&S FSQ26 with options R&S FSU-B25 R&S FSQ K7	1166.3311.26 1044.9298.02 1157.1955.26  1155.5001.26 1044.9298.02 1141.1796.02
19	Feed-through termination	50 Ω, BNC system	R&S RAD	0289.8966.00

## Test Assemblies

### Standard Test Assembly for Analog Modulations

Test equipment	<ul style="list-style-type: none"> <li>- RF analyzer (<a href="#">Table 1-1</a>, item 18)</li> <li>- Signal generator (<a href="#">Table 1-1</a>, item 5)</li> </ul>
Test setup	The RF analyzer is used as a modulation analyzer. The signal generator is used as modulation source in case of external modulation.
	<p>The diagram illustrates the test setup for analog modulations. It consists of three main components: a Signal Generator, a DUT (Device Under Test), and an RF Analyzer. A 10 MHz reference signal is provided to both the Signal Generator and the DUT. The Signal Generator outputs an LF (Low Frequency) signal to the DUT. The DUT outputs an RF (Radio Frequency) signal to the RF Analyzer. The RF Analyzer also receives a 10 MHz reference signal.</p>

### Test Assembly for Pulse Modulation

<p>Test equipment</p>	<ul style="list-style-type: none"> <li>- Oscilloscope (<a href="#">Table 1-1</a>, item 3)</li> <li>- Signal generator (<a href="#">Table 1-1</a>, item 5)</li> <li>- Mixer</li> </ul>
<p>Test setup</p>	<p>The pulsed RF is mixed down to DC in phase and analyzed with an oscilloscope.</p>

### Test Assembly for Residual AM

<p>Test equipment</p>	<ul style="list-style-type: none"> <li>- RF analyzer (<a href="#">Table 1-1</a>, item 18)</li> <li>- Zero Bias Schottky Detector (<a href="#">Table 1-1</a>, item 20)</li> <li>- Low Noise Preamplifier 10 Hz – 30kHz, &gt;30dB Gain (<a href="#">Table 1-1</a>, item 9)</li> </ul>
<p>Test setup</p>	

### Test Assembly for SSB Phase Noise and Jitter

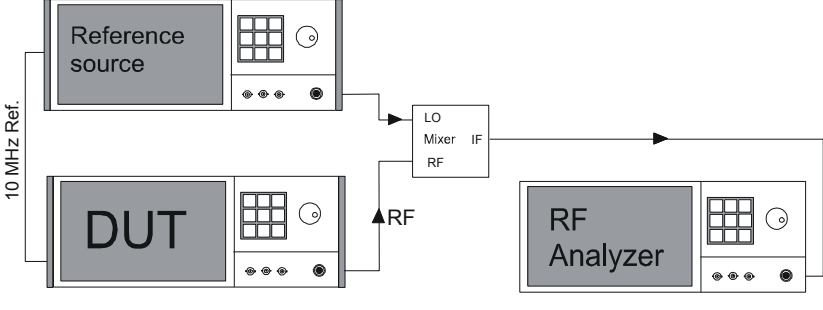
Test equipment	<ul style="list-style-type: none"> <li>- SSB reference source (<a href="#">Table 1-1</a> item 2),</li> <li>- Phase noise test assembly consisting of</li> <li>- Spectrum analyzer (<a href="#">Table 1-1</a> item 18)</li> </ul>
Test setup	

### Test Assembly for Output Impedance (VSWR)

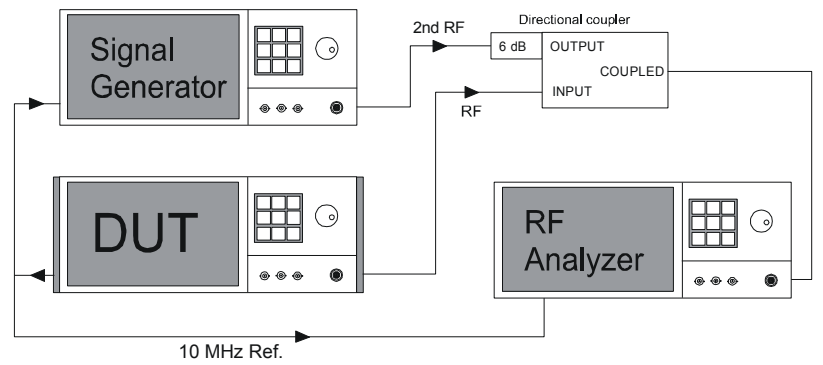
Test equipment	<ul style="list-style-type: none"> <li>- VSWR bridge (<a href="#">Table 1-1</a>, item 10),</li> <li>- Second signal generator (<a href="#">Table 1-1</a>, item 5)</li> <li>- Spectrum analyzer (<a href="#">Table 1-1</a>, item 18)</li> </ul>
Test setup	
	<p><b>Note:</b> The INPUT of the directional coupler is directly screwed to the DUT. The second signal generator is connected to the line connector (OUTPUT), the analyzer to the coupling output (COUPLED) of the directional coupler.</p>

### Test Assembly for Setting Time

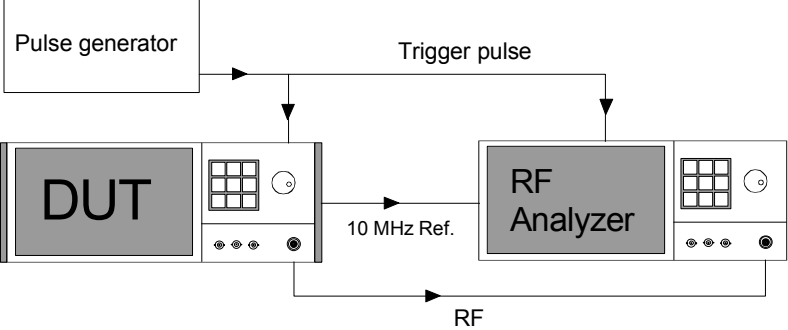
Test equipment	<ul style="list-style-type: none"><li>- Spectrum analyzer (<a href="#">Table 1-1</a>, item 18)</li><li>- Pulse generator (<a href="#">Table 1-1</a>, item 13)</li></ul>
Test setup	 <p>The diagram illustrates the test setup for setting time. It features three main components: a Pulse generator, a DUT (Device Under Test), and an RF Analyzer. The Pulse generator is connected to the input of the DUT. The output of the DUT is connected to the input of the RF Analyzer. A 10 MHz reference signal is also connected to the RF Analyzer. A Trigger pulse signal is sent from the Pulse generator to the RF Analyzer. The RF signal from the DUT is labeled as RF.</p>

## Preparation, Recommended Test Frequencies and Levels

To ensure proper conditions for the performance test and prevent setting errors, the instrument must be prepared as follows:

- Allow for a minimum **warm-up time of 30 minutes** at ambient temperature.
- Carry out all **internal adjustments** (see operating manual, chapter 4, section "Internal Adjustment - Setup-System").
- Press **PRESET** to establish a defined **initial** state before configuring a new measurement.

The following sections describe the **procedures** for checking the rated values. The **values** are specified in the **data sheet**. Additional uncertainties introduced by the measurement equipment must be taken into account when checking the rated values.

The following table lists the important internal switch point frequencies and the recommended measurement frequencies derived from these frequencies. We recommend measurements at these frequencies unless particular test frequencies are specified. In the following,  $RF_{max}$  is the maximal settable RF (depending on installed options).

Table 1-2 Range limits, main test frequencies for CW Mode

Range	Frequency	Hardware switching points	Recommended test frequencies
Direct DDS Synthesis	$9 \text{ kHz} \leq f \leq 23.4375 \text{ MHz}$	23.4375 MHz	9 kHz; 200 kHz; 1 MHz; 5 MHz; 10 MHz; 23.4375 MHz
Divider/128	$23.4375 \text{ MHz} < f \leq 25 \text{ MHz}$	25 MHz	23.438 MHz; 24.999 MHz
Divider /64	$25 \text{ MHz} < f \leq 50 \text{ MHz}$	32 MHz; 50 MHz	25.01 MHz; 31.99 MHz; 49.99 MHz
Divider /32	$50 \text{ MHz} < f \leq 100 \text{ MHz}$	71 MHz; 100 MHz	50.01 MHz; 70.9 MHz; 99.9 MHz
Divider /16	$100 \text{ MHz} < f \leq 200 \text{ MHz}$	141 MHz; 200 MHz	100.1 MHz; 140.9 MHz; 199.9 MHz
Divider /8	$200 \text{ MHz} < f \leq 400 \text{ MHz}$	283 MHz; 400 MHz	200.1 MHz; 282.9 MHz; 399.9 MHz
Divider /4	$400 \text{ MHz} < f \leq 800 \text{ MHz}$	566 MHz; 800 MHz	400.1 MHz; 565.9 MHz; 799.9 MHz
Divider /2	$800 \text{ MHz} < f \leq 1.6 \text{ GHz}$	1131 MHz; 1600 MHz	800.1 MHz; 1100 MHz; 1130.9 MHz; 1599.9 MHz
Base octave	$1.6 \text{ GHz} < f \leq 3.2 \text{ GHz}$	2263 MHz	1600.1 MHz; 2262.9 MHz; 3.2 GHz

$RF_{max}$  ist the maximum output frequency of the instrument according to its frequency option (1.1 GHz or 3.2 GHz).

For **high-resolution measurements** in the entire frequency range, a logarithmic frequency grid in 1-2-5 sequence is recommended up to 50 MHz; above this value, linear 50 MHz steps should be used up to the upper limit frequency.

The recommended **test levels** are at the upper and lower switching threshold of the attenuator. The electronic attenuator of the DUT is switched depending on frequency, modulation parameters and level according to an internal stored table in approximately 4 dB steps. The switching thresholds can be detected under **Attenuator fixed range** in the **Level** menu. After setting all other parameters, the threshold level can be detected by level variation. The level at which the attenuator fixed range changes is the threshold. By measuring at the last level setting of one range and the first level setting of the next range, the internal setting range borders are used. In the following,  $P_{min}$  is the lowest level before switching the attenuator, and  $P_{max}$  the highest.

## Test Procedures

### Reference Frequency

#### Output of Internal Reference

**Important:** Allow the DUT to warm up for at least 2 hours before the measurement.

Test equipment	Frequency counter ( <a href="#">Table 1-1</a> , item 1)
Test setup	➤ Connect a calibrated frequency counter to the REF OUT output (on rear panel).
Measurement	➤ Measure the frequency. ⇒ The frequency deviation must not exceed the sum of deviations resulting from the frequency error in the rated temperature range and from aging.



### Input for External Reference

Test equipment	<ul style="list-style-type: none"> <li>- Frequency counter (<a href="#">Table 1-1</a>, item 1)</li> <li>- Signal generator (<a href="#">Table 1-1</a>, item 5)</li> </ul>						
Test method	The external reference input frequency of the DUT is varied according to the data sheet and the RF output signal frequency is controlled with a frequency counter to follow this variation.						
Preparation of measurement	<ul style="list-style-type: none"> <li>➤ Connect the signal generator RF output to the REF IN input for the external reference (on rear panel) of the DUT. Connect a calibrated frequency counter to the RF output. Synchronize the signal generator and the frequency counter.</li> <li>➤ Setting on DUT: <ul style="list-style-type: none"> <li>- RF on</li> <li>- Level: 0 dBm (suitable level for the frequency counter)</li> <li>- Frequency: 1 GHz</li> <li>- Setup ⇒ Reference Oscillator ⇒ Source: External</li> </ul> </li> <li>➤ Setting on signal generator: <ul style="list-style-type: none"> <li>- RF on</li> <li>- Level: 0 dBm</li> </ul> </li> </ul>						
Measurement	<ul style="list-style-type: none"> <li>➤ Set the signal generator frequency to 9.99997 MHz and 10.0003 MHz. Measure the output frequency of the DUT.</li> </ul> <table border="1" style="margin-left: 20px;"> <tr> <td>Signal generator frequency</td> <td>9.99997 MHz</td> <td>10.0003 MHz</td> </tr> <tr> <td>DUT frequency</td> <td>999.997 MHz</td> <td>1000.03 MHz</td> </tr> </table> <p>There must be no relative frequency error and no error message in the display of the DUT.</p>	Signal generator frequency	9.99997 MHz	10.0003 MHz	DUT frequency	999.997 MHz	1000.03 MHz
Signal generator frequency	9.99997 MHz	10.0003 MHz					
DUT frequency	999.997 MHz	1000.03 MHz					

## Frequency

### Frequency Setting

Test equipment	
Test method	The frequency setting is checked by running the internal synthesizer adjustments to check the frequency overlap of the VCOs.
Measurement	<ul style="list-style-type: none"> <li>➤ Run: Setup ⇒ Internal Adjustments ⇒ Adjust Synthesis</li> </ul> <p>There must be no error message.</p>

**Setting Time (only for Option R&S SMC-K4)**

Test assembly	See section " <a href="#">Test Assembly for Setting Time</a> ", page 1.5. For measuring after IEC/IEEE bus delimiter the EOI-line of the IEC/IEEE bus is used as trigger signal instead of the pulse generator.
Test method	The spectrum analyzer operates as an FM demodulator. A controller transmits the start and the stop frequency via the IEC/IEEE bus. The analyzer is triggered by the positive edge on the EOI line of the IEC/IEEE bus or the trigger pulse in list mode. At switch over from start to stop frequency, the settling procedure is displayed on the screen of the analyzer.
Preparation of measurement	<ul style="list-style-type: none"> <li>➤ Synchronize the reference frequencies of the DUT and the analyzer.</li> <li>➤ Make IEC/IEEE bus and RF connections.</li> <li>➤ Connect spectrum analyzers trigger connector to EOI line (pin 5) of IEC/IEEE bus.</li> <li>➤ Settings on DUT:             <ul style="list-style-type: none"> <li>- <b>Frequency:</b> start frequency unmodulated,</li> <li>- <b>Level:</b> 0 dBm</li> </ul> </li> <li>➤ Settings on spectrum analyzer:             <ul style="list-style-type: none"> <li>- AMPT/REF LEVEL 0 dBm</li> <li>- FREQ/CENTER/STOP FREQUENCY</li> <li>- FM DEMOD ON</li> <li>- DEMOD BW 50 kHz</li> <li>- RANGE /DEVIATION PER DIV 200 Hz</li> <li>- MEAS TIME 10 ms</li> <li>- TRIGGER EXTERN</li> <li>- External triggering by positive edge at 1.4 V.</li> </ul> </li> </ul>
Measurement	<ul style="list-style-type: none"> <li>➤ Settings on analyzer: - Set the analyzer to the stop frequency</li> <li>➤ Set the DUT to the start frequency <math>f_{start}</math></li> <li>➤ Send the stop frequency <math>f_{stop}</math> from the controller to the DUT.             <ul style="list-style-type: none"> <li>⇒ The externally triggered analyzer displays the settling curve. The setting time is defined as the time from which on the frequency deviation from the stop frequency is less than the specified deviation in the data sheet.</li> </ul> </li> <li>➤ Repeat the measurement with ALC state Off:             <ul style="list-style-type: none"> <li>⇒ RF ⇒ Automatic Level Control ⇒ State ⇒ OFF (Sample &amp; Hold)</li> </ul> </li> </ul>

	<table border="1" style="width: 100%; border-collapse: collapse;"> <thead> <tr> <th style="text-align: center;"><math>f_{start}</math></th> <th style="text-align: center;"><math>f_{stop}</math></th> <th style="text-align: center;">Deviation</th> </tr> </thead> <tbody> <tr> <td style="text-align: center;">23.4 MHz</td> <td style="text-align: center;">1100 MHz</td> <td style="text-align: center;">±110 Hz</td> </tr> <tr> <td style="text-align: center;">799.9 MHz</td> <td style="text-align: center;">800.1 MHz</td> <td style="text-align: center;">±80 Hz</td> </tr> </tbody> </table>	$f_{start}$	$f_{stop}$	Deviation	23.4 MHz	1100 MHz	±110 Hz	799.9 MHz	800.1 MHz	±80 Hz
$f_{start}$	$f_{stop}$	Deviation								
23.4 MHz	1100 MHz	±110 Hz								
799.9 MHz	800.1 MHz	±80 Hz								

Example of Measurement:

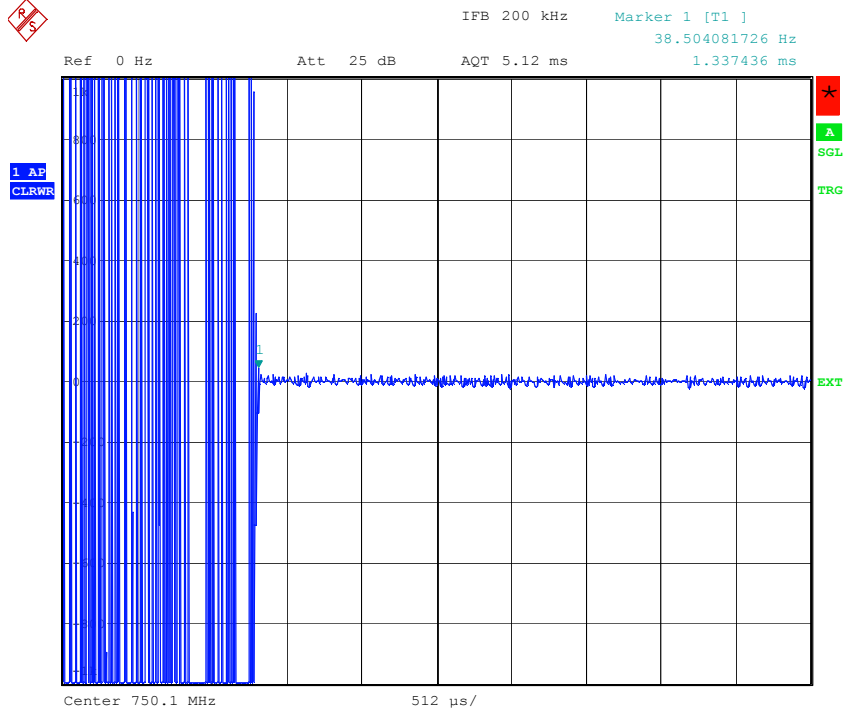

Date: 14.FEB.2008 18:58:23

The marker is set to the time when the trace enters the specified interval of 750.1 MHz ± 75 Hz. The setting time is 1.34 ms.

## Spectral Purity

### Harmonics

Test equipment	Spectrum analyzer ( <a href="#">Table 1-1</a> , item 18)
Test setup	<ul style="list-style-type: none"> <li>➤ Connect the spectrum analyzer to the RF output of the DUT.</li> <li>➤ Synchronize the reference frequencies of analyzer and DUT.</li> </ul>
Measurement	<ul style="list-style-type: none"> <li>➤ Settings on analyzer: Reference level = 20 dBm, 10 dB/div. Span 0 Hz, Resolution bandwidth 10 kHz</li> <li>➤ Settings on DUT: - <b>Frequency:</b> test frequencies, unmodulated - <b>Level:</b> test levels</li> <li>➤ First measure the level of the fundamental <math>P_f</math> at the test frequency <math>f</math> as a reference. Then measure the signal levels <math>P_{2*f}</math> and <math>P_{3*f}</math> at twice and three times the carrier frequency <math>f</math>. ⇒ The harmonic spacing is the measured harmonic level referred to the fundamental: HD2 = <math>P_f - P_{2*f}</math> HD3 = <math>P_f - P_{3*f}</math> (in dBc = referred to the carrier)</li> </ul>
Recommended test frequencies and levels	<p>Test frequencies: 1 MHz, 32.1 MHz, 71.1 MHz, 141.1 MHz, 283.1 MHz, 567 MHz, 1132 MHz, 2264 MHz</p> <p>Test level: +8dBm</p>

**Nonharmonics**

Test equipment	Same as for harmonics
Test setup	Same as for harmonics
Measurement	<ul style="list-style-type: none"> <li>➤ Setting on analyzer: Reference level = 0 dBm, 10 dB/div. Span 50 Hz, Resolution bandwidth 10 Hz</li> <li>➤ Setting on DUT Level = 0 dBm</li> <li>➤ First the carrier level <math>P_f</math> is measured at the test frequency <math>f</math> as reference and then the signal level <math>P_{search}</math> is measured at the analyzer search frequency. <ul style="list-style-type: none"> <li>⇒ The nonharmonic spacing <math>D</math> is the measured level referred to the reference level:  <math>D = P_f - P_{search}</math>  (in dBc = referred to the carrier)</li> </ul> </li> </ul>
	<p><b>Note:</b>  <i>Some of the nonharmonics suppression values measured might be outside the analyzer specifications. In case of doubt, repeat the measurement with a 3 dB attenuator at the analyzer input. If the nonharmonic spacing changes the nonharmonic is due to the analyzer.</i></p> <p><b>Alternative:</b>  <i>Check with a second source with differing synthesizer architecture (not a R&amp;S SMC).</i></p>

**Recommended settings and search frequencies:**

DUT Frequency	Analyzer search frequency
13 MHz	9 MHz
13 MHz	22 MHz
17 MHz	15 MHz
23.4375 MHz	6.25 MHz
23.4375 MHz	29.6875 MHz
1087.732 MHz	1087.796 MHz
3075.656 MHz	3075.72 MHz

## Non-systematic nonharmonics

### Measurement

- Settings on DUT:
  - Test frequency 1 GHz
  - Test level 0dBm unmodulated
- Recommended settings on analyzer:
  - Max peak detector
  - Filter Type: FFT
  - Ref-Level 0 dBm
- - Set analyzer center frequency to 1 GHz, span to 40 MHz and resolution bandwidth to 2 kHz
  - Measure carrier level P
  - all signals other than the carrier must be below P – 60 dB
- Set analyzer span to 100 kHz and resolution bandwidth to 200 Hz
  - all signals other than the carrier must be below P – 60 dB

---

**Note:**

*Some of the nonharmonics suppression values to be measured might be outside analyzer specifications. In case of doubt, repeat the measurement with a 3 dB attenuator pad at the analyzer input. If the nonharmonics suppression changes the nonharmonics are due to the analyzer. Because of the bell-shaped noise of the analyzer near the carrier, smaller resolution bandwidths may have to be used. To exclude amplitude independent nonharmonics of the analyzer, use a second generator with different synthesis architecture.*

---

Wideband Noise

Test assembly	Connect spectrum analyzer to RF socket of the DUT.
Test method	The carrier power is measured first. Then the center frequency of the analyzer is increased by 10 MHz and the noise power in a small bandwidth is measured. The difference of the carrier power and the noise power in 1 Hz bandwidth, which is calculated from the measurement, is defined as wideband noise. Because wideband noise degrades with lower electronic levels in front of the output step attenuator the output level of the generator has to be set to the lowest level before switching the step attenuator.
Measurement	<ul style="list-style-type: none"> <li>➤ Settings on DUT:             <ul style="list-style-type: none"> <li>- frequency: test frequency</li> <li>- Level: 0 dBm</li> <li>- determine Att-fixed range upper Level <math>P_{upper}</math>:</li> <li>- <math>\Rightarrow</math> RF <math>\Rightarrow</math> Level <math>\Rightarrow</math> Att fixed range <math>\Rightarrow</math> upper</li> <li>- set level to <math>P_{upper} + 0.1</math> dB</li> </ul> </li> <li>➤ Settings on analyzer:             <ul style="list-style-type: none"> <li>- center: test frequency</li> <li>- reference level <math>P_{upper} + 1</math> dB</li> <li>- Attenuator <math>D_{min} = P_{upper} - P_{1dBm} + 5dB \Rightarrow</math> round to next larger available Attenuation of the analyzer (<math>P_{1dBm}</math> = analyzer P1dB level at test frequency)</li> <li>- span 110 kHz</li> <li>- Detector RMS</li> <li>- Sweep Time Manual 1s</li> <li>- switch on channel power measurement with 100 kHz bandwidth</li> </ul> </li> <li>➤ Determine the channel power with the center frequency of the analyzer set to the test frequency and note it down as <math>P_{ref}</math>.</li> <li>➤ Increase the analyzer center frequency by 9.9 MHz.</li> <li>➤ Inhibit the switching of the attenuator with AMPT RF ATTEN MANUAL without entering a value so that the input mixer is not overdriven.</li> <li>➤ Lower the reference level of the analyzer by 20 dB, read the new channel power <math>P_{noise}</math>.</li> <li>➤ Minimize the output level on the DUT by means of RF OFF, read the channel power <math>P_{res}</math>.</li> </ul>
Evaluation	<ul style="list-style-type: none"> <li>➤ If the power <math>P_{res} &lt; P_{noise} - 0.41</math> dB the inherent noise power of the analyzer can be subtracted:             <div style="border: 1px solid black; padding: 5px; margin: 10px 0;"> <math display="block">Wideband\_Noise = -P_{ref} + \log_{10}(10^{P_{noise}} - 10^{P_{res}}) - 50dB</math> </div> </li> <li>➤ If the power <math>P_{res} &gt; P_{noise} - 0.41</math> dB the analyzer resolution is not sufficient for a precise measurement. The true result is in such case certainly more than 10 dB below the measured value. The result than is at least:             <div style="border: 1px solid black; padding: 5px; margin: 10px 0;"> <math display="block">Wideband\_Noise = -P_{ref} + P_{noise} - 50dB - 10dB</math> </div> </li> </ul> <p><math>\Rightarrow</math> The difference between the (possibly corrected) power <math>P_{noise}</math> in dBm and the power <math>P_{ref}</math> in dBm is the broadband noise floor in dBc.</p>
Recommended test frequencies	➤ 1.02 MHz, 23.438 MHz; 51 MHz, 101 MHz, 201 MHz, 401 MHz, 801 MHz, 1100 MHz, 1601 MHz, 2200 MHz and 3200 MHz

## SSB Phase Noise

The SSB phase noise of the DUT can be measured direct if a Phase Noise Test Set is available. An R&S FSUP or any other analyzer with phase noise option is suitable if its own phase noise is at least 6 dB less than the guaranteed DUT Phase noise in the data sheet.

Measurement: Set the Level of the DUT to 0 dBm and measure the phase noise at 20 kHz offset with the analyzer in phase noise mode.

If no suited analyzer is available, the Phase noise can be measured with the aid of a second generator and a mixer:

Test assembly	See section "Test Assembly for SSB Phase Noise and Jitter", page 1.4.
Test method	The two generators are set to the test frequency and synchronized with a phase offset of 90° (phase quadrature). Mixing to 0 Hz suppresses the RF carrier. Due to the phase quadrature, the mixer supplies a voltage representing the phase difference between the input signals. This voltage is measured with the spectrum analyzer.
Measurement	<ul style="list-style-type: none"> <li>➤ Set the levels of the two generators in accordance with the specifications of the mixer used. (For the MITEQ-DB0118 mixer set the LO-level to +10 dBm and the RF-level to 0 dBm.)</li> <li>➤ Settings of the DUT: <ul style="list-style-type: none"> <li>- PM int</li> <li>- PM deviation 0.01 rad</li> <li>- Modulation frequency 19 kHz</li> </ul> </li> <li>➤ Settings on the analyzer: <ul style="list-style-type: none"> <li>- Center frequency 19.5 kHz</li> <li>- Span 2 kHz</li> <li>- Input coupling DC</li> <li>- Attenuator manual 0 dB</li> <li>- average on, count = 10</li> <li>- average mode: linear/ power</li> <li>- Filter Type: FFT</li> <li>- Resolution Bandwidth 10 Hz</li> <li>- set marker to 19 kHz.</li> <li>- set delta marker to 20 kHz</li> </ul> </li> <li>➤ Adjust the phase of the DUT for phase quadrature: Set the Delta Phase in the Frequency/Phase menu for maximum marker readout at 19 kHz in the Delta Phase range of 0° to 180°. Note down the relative Delta marker level D.</li> <li>➤ Calculate the SSB phase noise in dbc/Hz: <ul style="list-style-type: none"> <li>- The Delta Marker measures the noise in 10 Hz bandwidth. The power in 1 Hz bandwidth is one tenth of this power: <math>\log_{10}(10)</math></li> <li>- The PM with a modulation rate of 0.01 rad is equivalent to a phase noise of -46 dBc.</li> <li>- In baseband the two sidebands fall on each other: -6dB</li> <li>- The phase noises of the two generators add together: - 3dB if they are of the same type.</li> </ul> <p>If the reference generator is of the same type as the DUT:  <math>PN = D - 10 * \log_{10}(10) - 46 \text{ dB} - 6 \text{ dB} - 3 \text{ dB}</math>  <math>PN = D - 65 \text{ dB}</math></p> <p>If the phase noise of the reference generator is at least 10 dB better than the phase noise of the DUT:  <math>PN = D - \log_{10}(10) - 46 \text{ dB} - 6 \text{ dB}</math>  <math>PN = D - 62 \text{ dB}</math></p> </li> </ul>
Recommended test frequencies	1 GHz, RFmax



Residual FM

Example:

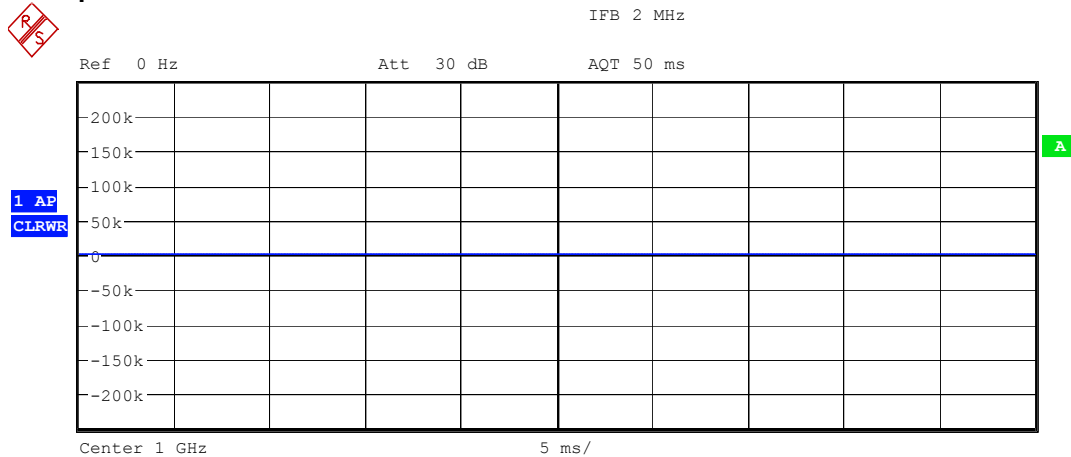

Frequency Modulation Summary

Coupling	DC	Carrier Offset	45.639 Hz
Deviation	+peak 12.93 Hz	Carrier Power	-0.91 dBm
	-peak -12.41 Hz	Modulation Frequency	--- Hz
	±peak/2 12.67 Hz	Sampling Rate	250 kHz
	RMS 3.465 Hz	Record Length	12501
		Demod Bandwidth	200 kHz
		AF Filter	HP 20 Hz
			LP 23 kHz

Date: 22.FEB.2008 17:35:25

Residual FM = 3.465 Hz

Residual AM

Example:

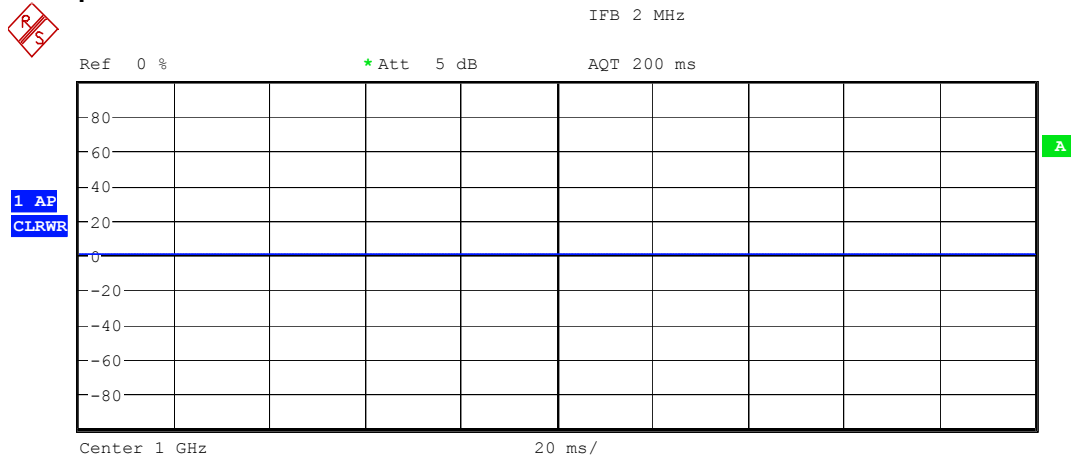

1 AP  
 CLRWR

Amplitude Modulation Summary

Modulation Depth	0.022 %	Carrier Power	-0.87 dBm
Modulation +peak	0.022 %	Modulation Frequency	--- Hz
-peak	-0.023 %	Sampling Rate	250 kHz
±peak/2	0.022 %	Record Length	50001
RMS	0.005 %	Demod Bandwidth	200 kHz
		AF Filter	HP 20 Hz LP 23 kHz

Date: 25.FEB.2008 16:33:44

Residual AM = 0.005 %

**Level Data**

**Level Uncertainty**

Test method	The level uncertainty is measured in two steps. First, the <b>frequency response</b> is measured at a fixed level with high frequency resolution. Then the <b>level dependant uncertainty</b> is measured at fixed frequencies over the specified range.
Test equipment	<ul style="list-style-type: none"> <li>- Power meter (<a href="#">Table 1-1</a>, item 8)</li> <li>- Spectrum analyzer (<a href="#">Table 1-1</a>, item 18)</li> <li>- Low-noise preamplifier (<a href="#">Table 1-1</a>, item 9)</li> </ul>

Test method for levels in measurement range of power meter

Test setup	Connect power meter to RF output socket.
Measurement	<ul style="list-style-type: none"> <li>➤ Setting on DUT:             <ul style="list-style-type: none"> <li>- <b>Levels :</b> +13 dBm in level Mode AUTO</li> </ul> </li> <li>➤ Measure the level <math>P_{absolute}</math> at the recommended test frequencies up to <math>RF_{max}</math>.             <ul style="list-style-type: none"> <li>⇒ The level error is the deviation of the measured level from the set value.</li> </ul> </li> <li>➤ Repeat this measurement at + 13 dBm in level Mode OFF (Sample &amp; Hold) at 200 kHz, 25 MHz, 100 MHz, 1.1 GHz, 2.2 GHz and 3.2 GHz</li> </ul>
Recommended test frequencies for the level frequency response measurement	200 kHz, 500 kHz, 1 MHz; 5 MHz; 10 MHz; 23.4375 MHz 25 MHz to 95 MHz in 10 MHz Steps 112.5 MHz to 3.2 GHz in 25 MHz Steps

## Test method for low levels

Test principle	<p>Low levels can only be measured using a frequency selective measurement instrument. Spectrum analyzers with digital IF are best suited for this measurement due to their low linearity error. The absolute accuracy of these analyzers is not sufficient for this measurement. So a relative measurement referred to the measurements performed with the power meter is used to increase the accuracy of the measurement.</p> <p>Only by switching the input attenuator and preamplifier (when available) of the analyzer the needed dynamic range of more than 120 dB can be reached. After switching the analyzer attenuator or preamplifier, a continuity calibration is to be carried out. It is therefore recommended to switch the attenuator not until reaching 50 dB under full scale, since the linearity errors are very small in this range.</p>
Test setup	<ul style="list-style-type: none"> <li>➤ Connect the spectrum analyzer to the RF output of the DUT with <b>hermetically sealed RF measurement cables</b>.</li> </ul>
Measurement	<ul style="list-style-type: none"> <li>➤ Settings on DUT <b>Frequency</b> recommended test frequencies <b>Level</b> +13 dBm, unmodulated</li> <li>➤ Setting on the analyzer Test frequency SPAN 10 Hz FILTER TYPE FFT RES BW 5 Hz set Marker to test frequency Reference level <math>P_{ref} = +15</math> dBm</li> <li>➤ Read the marker level <math>P_{Marker}</math> and calculate the correction factor <math display="block">C = P_{absolute} - P_{Marker}</math> with <math>P_{absolute}</math> from the measurements performed with the power meter.</li> <li>➤ Now decrease the DUT level in 5 dB steps and calculate the output power P by adding the Correction factor C to the marker readout.</li> <li>➤ As soon as the marker level <math>P_{Att1}</math> is lower than <math>P_{ref} -45</math> dB increase the sensitivity of the analyzer by reducing the input attenuation, switching on the internal preamplifier if available and reducing the resolution bandwidth to 1 Hz for levels below -90 dBm. Set the analyzer reference level to <math>P_{Att1} + 1</math> dB. After switching the analyzer sensitivity read out the marker level <math>P_{Att2}</math> and recalculate the Correction factor: <math display="block">C_{new} = C_{old} + P_{Att1} - P_{Att2}</math></li> <li>➤ Continue the measurement down to -120 dBm in 5 dB steps.</li> </ul>
Recommended test frequencies.	1 MHz, 512.5 MHz, 1087.5 MHz, 2187.5 MHz, 3187.5 MHz

Output Impedance

Test assembly	" <a href="#">Test Assembly for Output Impedance (VSWR)</a> " (page 1.4)
Test method	For the VSWR measurement of a source the effect of the level control must be taken into account. For this purpose, an auxiliary generator is used which transmits a wave with a slightly offset carrier frequency into the DUT. The difference frequency has to be within the control bandwidth of the level control. In the case of ideal source impedance, the wave from the auxiliary generator is not reflected by the DUT. In the case of not ideal DUT source impedance, the output wave of the DUT and the reflected wave of the auxiliary generator are superimposed on one another. A directional coupler couples a part of these outgoing superimposed waves to an analyzer. The frequency offset, results in a beat of the superimposed outgoing waves. The VSWR is the ratio between the maximum and minimum amplitude of the beat.
Measurement	<ul style="list-style-type: none"> <li>➤ Settings on DUT:             <ul style="list-style-type: none"> <li>- <b>Level:</b> test level</li> <li>- <b>Frequency:</b> test frequency, unmodulated</li> </ul> </li> <li>➤ Settings on spectrum analyzer:             <ul style="list-style-type: none"> <li>- Test frequency, span 0 Hz, test level</li> <li>- Resolution and video bandwidth 10 kHz</li> <li>- Linear level scale</li> <li>- Sweep time 20 ms</li> </ul> </li> <li>➤ Settings on second signal generator:             <ul style="list-style-type: none"> <li>- set the frequency to the test frequency – 100 Hz,</li> <li>- set minimum level, unmodulated.</li> </ul> </li> <li>➤ Vary the reference level to bring the line displayed on the screen of the spectrum analyzer approximately into the middle of the screen. Measure the voltage of the signal <math>V_{ref}</math>.</li> <li>➤ Unscrew the VSWR bridge from the DUT and let the test port open. Increase the level of the second signal generator until the voltage on the analyzer is <math>V_{ref} \pm 0.5\%</math>.</li> <li>➤ Screw the VSWR bridge onto the DUT again.</li> <li>➤ Measure the maximum voltage <math>V_{max}</math> and minimum voltage <math>V_{min}</math> of the sinusoidal trace. Calculate the VSWR:  <math display="block">VSWR = V_{max}/V_{min}</math> </li> </ul>
Recommended test frequencies and levels	<ul style="list-style-type: none"> <li>➤ Test frequencies: from 200 kHz every 50 MHz up to <math>RF_{max}</math>.</li> <li>➤ Test levels: +0 dBm and +13 dBm.</li> </ul>

**Setting Time (only for Option R&S SMC-K4)**

Test assembly	Connect the spectrum analyzer ( <i>Table 1-1</i> , item 18) to the RF connector of the DUT.						
Test method	The spectrum analyzer is operated as a fast level meter in zero span. A controller transfers the start and the stop level via the IEC/IEEE bus. The analyzer is triggered by the positive edge on the EOI line of the IEC/IEEE bus. At switch over from start to stop level, the settling procedure is displayed on the screen of the analyzer.						
Preparation of measurement	<ul style="list-style-type: none"> <li>➤ Synchronize the reference frequencies of the DUT and the analyzer.</li> <li>➤ Make IEC/IEEE bus and RF connections.</li> <li>➤ Connect spectrum analyzers trigger connector to EOI line (pin 5) of IEC/IEEE bus.</li> <li>➤ Setting on DUT:             <ul style="list-style-type: none"> <li>- <b>Frequency:</b> test frequency unmodulated,</li> <li>- <b>Level:</b> start level</li> </ul> </li> <li>➤ Settings on spectrum analyzer:             <ul style="list-style-type: none"> <li>- REFERENCE LEVEL: target level + 3 dB</li> <li>- AMPLITUDE LOG RANGE 10 dB</li> <li>- RESOLUTION BANDWIDTH 200 kHz</li> <li>- VIDEO BANDWIDTH 2 MHz</li> <li>- SPAN 0 Hz</li> <li>- SWEEP TIME: 10 ms</li> <li>- TRIGGER EXTERN</li> <li>- External triggering by positive edge at 1.4 V.</li> </ul> </li> </ul>						
Measurement	<ul style="list-style-type: none"> <li>➤ Send the stop level from the controller to the DUT.             <ul style="list-style-type: none"> <li>⇒ The externally triggered analyzer displays the settling curve. The setting time is defined as the time from which on the level deviation from the final level is less than the specified deviation in the data sheet.</li> </ul> </li> <li>➤ Measure the following steps with ALC state AUTO and with ALC state OFF (Sample &amp; Hold).</li> </ul>						
Recommended test frequencies and levels	Frequencies: 1 MHz, 30 MHz, 375 MHz, 1.1 GHz, 2.2 GHz and 3.2 GHz <table border="1" data-bbox="576 1485 1353 1581" style="margin-left: 20px;"> <thead> <tr> <th>Start level</th> <th>Stop level</th> </tr> </thead> <tbody> <tr> <td>-120 dBm</td> <td>+13 dBm</td> </tr> <tr> <td>-35 dBm</td> <td>-5 dBm</td> </tr> </tbody> </table>	Start level	Stop level	-120 dBm	+13 dBm	-35 dBm	-5 dBm
Start level	Stop level						
-120 dBm	+13 dBm						
-35 dBm	-5 dBm						

## Internal Modulation Generator

### Frequency accuracy

The LF-Generator is integrated into an FPGA clocked with the same reference frequency as the synthesizer. Therefore, the LF frequency has the same accuracy as the RF and has not to be measured.

### Distortions

Test equipment	Spectrum analyzer (Table 1-1, item 18)
Test method	The fundamental and harmonics of the LF-generator are measured with the analyzer. The analyzer calculates the Total Harmonic Distortion with the 'Harmonic Distortion' function.
Test setup	➤ Connect the spectrum analyzer to the LF socket of the DUT.
Measurement of frequency settings and distortion	<ul style="list-style-type: none"> <li>➤ Settings on DUT:  <b>LF Output</b> menu:  <b>LF Gen Voltage</b> 1 V  <b>LF Gen Frequency</b> 1 kHz</li> <li>➤ Settings of the spectrum analyzer:  <b>RF INPUT</b> DC  <b>AMPT REF LEVEL</b> 20 dBm  <b>FREQ CENTER</b> = LF Gen Frequency  <b>MEAS</b> ⇒ <b>HARMONIC DISTOR</b>  <b>RF ATTEN MANUAL</b> increase by 10 dB</li> <li>➤ Read the THD</li> <li>➤ repeat the measurement at the recommended test frequencies by changing the DUT LF Gen Frequency and the analyzer center frequency.</li> </ul>
Recommended test frequencies	1 kHz, 10 kHz

### Level Accuracy and Frequency response

Test equipment	AC voltmeter ( <i>Table 1-1</i> , item 14)
Test method	The output level of the LF Generator is measured direct with an AC voltmeter.
Test setup	➤ Connect the AC voltmeter to the LF socket of the DUT.
Measurement of Level Accuracy	➤ Settings on DUT: <b>LF Output</b> menu: <b>LF Gen Frequency</b> 1 kHz set <b>LF Output Voltage</b> to recommended levels and measure the output level
Recommended test levels for Level Accuracy	10 mV, 30 mV, 100 mV, 300 mV, 1 V and 2.55 V
Measurement	➤ Settings on DUT: <b>LF Output</b> menu: <b>LF Output Voltage</b> 1 V set <b>LF Gen Frequency</b> to recommended test frequencies and measure the output level ⇨ Determine the highest and the lowest level $V_{\max}$ and $V_{\min}$ . The frequency response in dB is defined as: $D = 20 \cdot \log_{10}(V_{\max}) - 20 \cdot \log_{10}(V_{\min})$
Recommended test frequencies	10 Hz, 1 kHz, 10 kHz, 100 kHz

**Note:**        *The settling time is a pure computer time and needs therefore not to be measured.*



## Amplitude Modulation

### AM Setting Uncertainty

Test assembly	See section " <a href="#">Standard Test Assembly for Analog Modulations</a> ", page 1.2.
Measurement of accuracy versus modulation depth	<ul style="list-style-type: none"> <li>➤ Settings on DUT:                     <ul style="list-style-type: none"> <li><b>RF On</b></li> <li><b>Frequency</b> 150 MHz</li> <li><b>Level:</b> 0 dBm</li> <li><b>Amplitude Modulation On</b></li> <li style="padding-left: 20px;"><b>AM Source Internal</b></li> <li style="padding-left: 40px;"><b>LF Gen Frequency</b> 1 kHz</li> </ul> </li> <li>➤ Settings on analyzer:                     <ul style="list-style-type: none"> <li><b>AMPTD</b> ⇒ <b>REF LEVEL</b> test level + 6 dB ,</li> <li><b>FREQ</b> ⇒ <b>CENTER</b> 150 MHz</li> <li><b>FM DEMOD,</b></li> <li style="padding-left: 20px;"><b>FMDEMOD ON,</b></li> <li style="padding-left: 20px;"><b>RESULT DISPLAY</b> ⇒ <b>AM</b></li> <li style="padding-left: 20px;"><b>DEMOD BW</b> 50 kHz (⇒ <del>3*</del> <math>f_{mod}</math>)</li> <li style="padding-left: 20px;"><b>RANGE</b> ⇒ <b>DEVIATION PER DIV</b> 20 %</li> <li style="padding-left: 20px;"><b>MEAS TIME</b> 100 ms (<del>3</del> <math>f_{mod}</math>)</li> </ul> </li> <li>➤ set the <b>AM Depth</b> to the recommended modulation depths and read the modulation depth <math>\pm peak/2</math> from the analyzer.</li> <li>➤ set DUT to                     <ul style="list-style-type: none"> <li><b>AM Source External,</b></li> <li><b>AM Ext Coupling AC,</b></li> <li><b>AM Depth 80%,</b></li> <li><b>LF Gen Output On,</b></li> </ul>                     Connect <b>LF</b> output to <b>MOD EXT</b> input and read the modulation depth <math>\pm peak/2</math> from the analyzer.                 </li> </ul>
Recommended modulation depths	m = 5%, 10 %, 20 %, 40 %, 60 %, 80 %

<p>Measurement of accuracy versus RF</p>	<ul style="list-style-type: none"><li>➤ Settings on DUT: <b>RF On</b> <b>Frequency</b> recommended test frequencies <b>Level:</b> 0 dBm <b>Amplitude Modulation On</b> <b>AM Source Internal</b>  <b>LF Gen Frequency</b> 1 kHz <b>AM Depth</b> 80 %</li><li>➤ Settings on analyzer: <b>AMPTD</b> ⇨ <b>REF LEVEL</b> 6 dBm, <b>FREQ</b> ⇨ <b>CENTER</b> same as DUT <b>FM DEMOD,</b> <b>FMDEMOD ON,</b> <b>RESULT DISPLAY</b> ⇨ <b>AM</b> <b>DEMOD BW</b> 50 kHz <b>RANGE</b> ⇨ <b>DEVIATION PER DIV</b> 20 % <b>MEAS TIME</b> 100 ms</li><li>➤ measure the modulation depth for all recommended test frequencies</li></ul>
<p>Recommended test frequencies</p>	<ul style="list-style-type: none"><li>➤ 100 kHz, 1MHz, 23.4375 MHz, 23.438 MHz, 99.9 MHz, 399.9 MHz, 1100 MHz, 1599.9 MHz, 1600.1 MHz, 2262.9 MHz, 3200 MHz</li></ul>

### AM Distortion

Test assembly	See section " <a href="#">Standard Test Assembly for Analog Modulations</a> ", page 1.2.
Measurement	<ul style="list-style-type: none"> <li>➤ Settings on DUT:               <ul style="list-style-type: none"> <li><b>RF On</b></li> <li><b>Level 0 dBm</b></li> <li><b>Amplitude Modulation menu:</b> <ul style="list-style-type: none"> <li><b>LF Gen Frequency 1 kHz</b></li> <li><b>Source Internal</b></li> <li><b>AM depth 30%.</b></li> </ul> </li> </ul> </li> <li>➤ Settings on R&amp;S FSQ:               <ul style="list-style-type: none"> <li><b>AMPTD / REF LEVEL 6 dBm,</b></li> <li><b>FREQ / CENTER test frequency</b></li> <li><b>FM DEMOD,</b></li> <li><b>FMDEMOD ON,</b></li> <li><b>RESULT DISPLAY ⇒ AM</b></li> <li><b>RESULT DISPLAY ⇒ AF SPECTRUM</b></li> <li><b>DEMOD BW &gt; 7* f<sub>mod</sub>,</b></li> <li><b>RANGE ⇒ DEVIATION PER DIV 20 %</b></li> <li><b>MEAS TIME 0.16 s</b></li> </ul> </li> </ul> <p>Measure the THD for all recommended test frequencies. To convert the displayed THD value in dB to percent calculate:  <math>THD_{pct} = 100 * 10^{(THD_{dB}/20)}</math>.</p>
Recommended test frequencies	<ul style="list-style-type: none"> <li>➤ 100 kHz, 1MHz, 23.4375 MHz, 23.438 MHz, 99.9 MHz, 399.9 MHz, 1100 MHz, 1599.9 MHz, 1600.1 MHz, 2262.9 MHz, 3200 MHz</li> </ul>

### AM Frequency Response

Test assembly	See section " <a href="#">Standard Test Assembly for Analog Modulations</a> ", page 1.2.												
Measurement	<ul style="list-style-type: none"> <li>➤ Settings on DUT: <ul style="list-style-type: none"> <li><b>RF On</b></li> <li><b>Level 0 dBm</b></li> <li><b>Amplitude Modulation menu:</b> <ul style="list-style-type: none"> <li><b>Source External</b></li> <li><b>External Coupling DC</b></li> <li><b>AM depth 60%.</b></li> </ul> </li> </ul> </li> <li>➤ Settings on R&amp;S FSQ: <ul style="list-style-type: none"> <li><b>AMPTD / REF LEVEL 6 dBm</b></li> <li><b>FREQ / CENTER test frequency</b></li> <li><b>FM DEMOD,</b></li> <li><b>FMDEMOD ON,</b></li> <li><b>RESULT DISPLAY ⇒ AM</b></li> <li><b>RESULT DISPLAY ⇒ AF SPECTRUM</b></li> <li><b>DEMOD BW 200 kHz,</b></li> <li><b>RANGE ⇒ DEVIATION PER DIV 20 %</b></li> <li><b>MEAS TIME ≥ 16/fmod s</b></li> </ul> </li> <li>➤ Vary the carrier frequency from 1 MHz to RF<sub>max</sub>. Recommended test frequencies 1 MHz, 99.9 MHz, 399.9 MHz, 799.9 MHz, 1100 MHz, 1599.9 MHz, 1600.1 MHz, 3200 MHz.</li> <li>➤ Settings on the signal generator: <ul style="list-style-type: none"> <li>- <b>LF Output ON</b></li> <li>- <b>LFGen Voltage 1 V (V<sub>peak</sub>).</b></li> <li>➤ Set the generator frequency to the frequencies given below and measure the modulation depth in RMS.</li> </ul> <table border="1" data-bbox="576 1257 1326 1353" style="width: 100%; border-collapse: collapse; text-align: center;"> <tr> <td style="padding: 2px;">Gen. frequency</td> <td style="padding: 2px;">10 Hz</td> <td style="padding: 2px;">100 Hz</td> <td style="padding: 2px;">1 kHz</td> <td style="padding: 2px;">10 kHz</td> <td style="padding: 2px;">50 kHz</td> </tr> <tr> <td style="padding: 2px;">MEAS TIME</td> <td style="padding: 2px;">1.6 s</td> <td style="padding: 2px;">0.2 s</td> <td style="padding: 2px;">0.2 s</td> <td style="padding: 2px;">0.2 s</td> <td style="padding: 2px;">0.2 s</td> </tr> </table> </li> <li>⇒ The modulation frequency response in dB is the difference between the greatest and the smallest modulation depth m<sub>max</sub> and m<sub>min</sub>:  <math display="block">m_{\max-\min} = 20 * \log_{10}(m_{\max}) - 20 * \log_{10}(m_{\min})</math> </li> </ul>	Gen. frequency	10 Hz	100 Hz	1 kHz	10 kHz	50 kHz	MEAS TIME	1.6 s	0.2 s	0.2 s	0.2 s	0.2 s
Gen. frequency	10 Hz	100 Hz	1 kHz	10 kHz	50 kHz								
MEAS TIME	1.6 s	0.2 s	0.2 s	0.2 s	0.2 s								
	<ul style="list-style-type: none"> <li>➤ Repeat the measurement at RF = 1 GHz with the setting <b>Amplitude Modulation ⇒ External Coupling AC</b></li> <li>➤ Repeat the measurement at RF = 1 GHz with the internal modulation generator with the setting <b>Amplitude Modulation ⇒ Source Internal.</b></li> </ul>												

### Synchronous PhiM with AM

<p>Test assembly</p>	<p>See section "<a href="#">Standard Test Assembly for Analog Modulations</a>", page 1.2.</p>
<ul style="list-style-type: none"> <li>➤ Measurement</li> </ul>	<ul style="list-style-type: none"> <li>➤ Settings on DUT:                     <ul style="list-style-type: none"> <li><b>RF On</b></li> <li><b>Level</b> PEP = <math>P_{max}</math> 0 dBm</li> <li><b>Amplitude Modulation</b> menu:                             <ul style="list-style-type: none"> <li><b>LF Gen Frequency</b> 1 kHz</li> <li><b>Source Internal</b></li> <li><b>AM depth</b> 30%.</li> </ul> </li> </ul> </li> <li>➤ Settings on spectrum analyzer                     <ul style="list-style-type: none"> <li><b>AMPTD / REF LEVEL</b> 3 dBm,</li> <li><b>FM DEMOD</b></li> <li><b>DEMOD BW</b> 12.5 kHz</li> <li><b>MEAS TIME</b> 100 ms</li> <li><b>RESULT DISPLAY</b> ⇨ <b>PM</b></li> </ul> </li> <li>➤ Recommended test frequencies.</li> <li>➤ Measure the resulting phase modulation with peak detection (<math>\pm peak/2</math>-value).</li> </ul>

## Frequency Modulation

### Test Methods

Test assembly	See section " <a href="#">Standard Test Assembly for Analog Modulations</a> ", page 1.2.
Test Method "FFT Demodulation (Option FS-K7)"	<ul style="list-style-type: none"> <li>• The FM deviation and distortion are determined by digital signal processing in the spectrum analyzer.</li> <li>➤ Settings on R&amp;S FSQ:             <ul style="list-style-type: none"> <li>AMPTD / REF LEVEL test level,</li> <li>FREQ / CENTER test frequency</li> <li>FMDEMOMOD,</li> <li>FMDEMOMOD ON,</li> <li>RESULT DISPLAY / FM resp. PM</li> <li>DEMOMOD BW &gt; 2 * (deviation + fmod) for FM,</li> <li>DEMOMOD BW &gt; 2 * fmod * (1 + deviation) for PM,</li> <li>RANGE / DEVIATION PER DIV 0.5 * deviation</li> <li>MEAS TIME 3/fmod</li> </ul> </li> <li>for distortion (up to 3<sup>rd</sup> harmonic)             <ul style="list-style-type: none"> <li>RESULT DISPLAY / FM resp. PM / AF SPECTRUM</li> <li>DEMOMOD BW &gt; 2 * (deviation + 3.5 * fmod) for FM,</li> <li>DEMOMOD BW &gt; 7 * fmod * (1 + deviation) for PM,</li> <li>MEAS TIME 16/fmod</li> </ul> </li> </ul>

### FM Setting Uncertainty

Test Method	➤ FFT Demodulation (see chapter " <a href="#">Test</a> ")
Measurement	<ul style="list-style-type: none"> <li>➤ Settings on DUT:             <ul style="list-style-type: none"> <li><b>RF On</b></li> <li><b>Level 0 dBm:</b></li> <li><b>Frequency Modulation menu:</b></li> <li><b>State on</b></li> <li><b>FM Source Internal</b></li> </ul> </li> </ul>
Recommended settings	<ul style="list-style-type: none"> <li>➤ Recommended test frequencies: 10 MHz, 1000 MHz with LFGen Freq = 1 kHz, FM Deviation = 100 kHz</li> <li>➤ Repeat measurement at 1000 MHz with changing settings to             <ul style="list-style-type: none"> <li><b>FM Source External</b></li> <li><b>FM Ext Coupling AC</b></li> </ul>             feed in a 1 kHz, 1Vp external modulation signal at the MOD EXT connector           </li> </ul>

## FM Distortion

Test Method	FFT Demodulation (see chapter " <a href="#">Test</a> ")
Measurement	<ul style="list-style-type: none"> <li>➤ Settings on DUT:  <b>RF On</b>  <b>Level 0 dBm:</b>  <b>Frequency Modulation</b> menu:  <b>State on</b>  <b>FM Source Internal</b>  <b>LFGen Frequency 2 kHz.</b> </li> <li>➤ Settings on R&amp;S FSQ:                      DEMOD BW 5 * FM deviation,                      RANGE / DEVIATION PER DIV 250 kHz,                      RESULT DISPLAY / FM, AF SPECTRUM,                      SWEEP / MEAS TIME 2.5 ms,                      FREQ / AF STOP 50 kHz.                 </li> <li>➤ Read the THD from the display. To convert to percent calculate  <math>THD_{pct} = 100 * 10^{(THD_{dB}/20)}</math>.                 </li> </ul>
Recommended settings	<ul style="list-style-type: none"> <li>➤ CF sweep                      Recommended test frequencies                      with FM deviation 250 kHz: 10 MHz,                      with FM deviation 500 kHz: 400.1 MHz, 533 MHz, 667 MHz, 800 MHz,                      with FM deviation 1 MHz: 1100 MHz,                      with FM deviation 2 MHz: 3200 MHz                 </li> </ul>

### FM Frequency Response

Test Method	FFT Demodulation (see chapter " <a href="#">Test</a> ")
Measurement	<ul style="list-style-type: none"> <li>➤ Settings on DUT:                     <ul style="list-style-type: none"> <li><b>RF On</b></li> <li><b>Level 0 dBm</b></li> <li><b>Frequency 23 MHz</b></li> <li><b>Frequency Modulation menu:</b> <ul style="list-style-type: none"> <li><b>FM Source External</b></li> <li><b>FM Ext Coupling DC</b></li> <li>FM deviation: 100 kHz</li> </ul> </li> </ul> </li> <li>➤ Setting on the signal generator:                     <p>The internal LF generator of the signal generator delivers the modulation signal to the external modulation input of the DUT. The level of the modulation signal is controlled by use of an AC voltmeter (Item 14 of Table 1-1 Measuring equipment and accessories).</p> <ul style="list-style-type: none"> <li>- LFGGen Voltage 1 V peak</li> <li>- State ON</li> </ul> </li> <li>➤ Settings on R&amp;S FSQ:                     <ul style="list-style-type: none"> <li>FFT Demodulation</li> </ul> </li> <li>➤ Vary the signal generator frequency and measure the modulation depth.</li> <li>⇨ The modulation frequency response is the factor between the greatest and the smallest modulation depth.</li> </ul>
Recommended settings	<ul style="list-style-type: none"> <li>➤ LF in logarithmic steps, 3 steps per decade (1, 2, 5) from 10 Hz to 100 kHz</li> <li>➤ Perform the measurement for test frequency 23 MHz.</li> <li>➤ Repeat the measurement with changing the settings to <b>FM Ext Coupling AC</b> for test frequency 23 MHz.</li> <li>➤ Repeat the measurement with changing the settings to <b>FM Ext Coupling AC</b> FM deviation: 500 kHz for test frequencies: 200.1 MHz, 266 MHz, 333 MHz, 400 MHz. LF sweep from 1 kHz to 100 kHz</li> <li>➤ Repeat the measurement with changing the settings to <b>FM Source Internal</b> <b>FM deviation: 500 kHz</b> at test frequency 400 MHz. LF sweep from 1 kHz to 100 kHz</li> </ul>



### Carrier Frequency Offset with FM

Test assembly	See section " <a href="#">Standard Test Assembly for Analog Modulations</a> ", page 1.2.
Measurement	<ul style="list-style-type: none"> <li>➤ Settings on DUT: <ul style="list-style-type: none"> <li><b>RF On</b></li> <li><b>Level</b> 0 dBm</li> <li>Frequency 1 GHz</li> <li><b>Frequency Modulation</b> menu: <ul style="list-style-type: none"> <li><b>State on</b></li> <li><b>FM Source Internal</b></li> <li><b>FM deviation</b> 1 MHz</li> <li>LFGen Frequency 10 kHz.</li> </ul> </li> </ul> </li> <li>➤ Settings on spectrum analyzer <ul style="list-style-type: none"> <li>AMPT / REF LEVEL 0 dBm</li> <li>FREQ / CENTER 1 GHz</li> <li>SPAN 10 kHz</li> <li>MKR / SIGNAL COUNT / NEXT / CNT RESOL 10 Hz</li> </ul> </li> <li>➤ Terminate the DUT External Modulation input with 50 Ω.and execute the internal FM offset adjustment.</li> <li>➤ Execute a single sweep. Using MKR→ / PEAK, read counted marker frequency. <ul style="list-style-type: none"> <li>⇒ The offset is the difference between marker frequency and set carrier frequency.</li> </ul> </li> <li>➤ Repeat measurement with FM source external, coupling ac and dc (2 measurements).</li> </ul>

## Phase Modulation

### PhiM Setting Uncertainty

Test Method	FFT Demodulation (see chapter " <a href="#">Test</a> ").
Measurement	<ul style="list-style-type: none"> <li>➤ Settings on DUT:  <b>RF On</b>  <b>Level 0 dBm</b>  <b>Phase Modulation</b> menu:  <b>State on</b>  <b>PhiM Source Internal</b>  <b>PhiM Deviation 2.5 rad</b>  <b>LFGGen Freq = 1 kHz</b> </li> <li>➤ Settings on spectrum analyzer:  see chapter "<a href="#">Test</a>" </li> </ul>
Recommended settings	<ul style="list-style-type: none"> <li>➤ Recommended test frequencies: 10 MHz and 400 MHz</li> <li>➤ Repeat measurement at 400 MHz with changing settings to  <b>PhiM Source External</b>  <b>PhiM Ext Coupling AC</b>  feed in a 1 kHz external modulation signal at MOD EXT connector </li> </ul>

**PhiM Distortion**

Test Method	FFT Demodulation (see chapter " <a href="#">Test</a> ")
Measurement	<ul style="list-style-type: none"> <li>➤ Settings on DUT:                     <ul style="list-style-type: none"> <li><b>RF On</b></li> <li><b>Level 0 dBm</b></li> <li><b>Phase Modulation</b> menu:                             <ul style="list-style-type: none"> <li><b>State on</b></li> <li><b>PhiM Source Internal</b></li> <li><b>LFGGen Frequency 10 kHz</b></li> </ul> </li> </ul> </li> <li>➤ Settings on R&amp;S FSQ:                     <ul style="list-style-type: none"> <li>see chapter "<a href="#">Test</a> "</li> <li>SWEEP / MEAS TIME 2.5 ms,</li> <li>FREQ / AF STOP 50 kHz,</li> <li>AMPTD / REF LEVEL 0 dBm,</li> <li>FREQ / CENTER test frequency.</li> </ul> </li> <li>➤ Read THD from the Display. To convert to percent calculate <math>THD_{pct} = 100 * 10^{(THD_{dB}/20)}</math>.</li> </ul>
Recommended settings	<ul style="list-style-type: none"> <li>➤ CF sweep</li> <li>Recommended test frequencies</li> <li>with PhiM deviation 2.5 rad: 10 MHz,</li> <li>with PhiM deviation 5 rad: 400.1 MHz, 533 MHz, 667 MHz, 800 MHz,</li> <li>with PhiM deviation 10 rad: 1100 MHz,</li> <li>with PhiM deviation 20 rad: 3200 MHz</li> </ul>

## PhiM Frequency Response

Test method	FFT Demodulation (see chapter " <a href="#">Test</a> ").
Measurement	<ul style="list-style-type: none"> <li>➤ Settings on DUT: <ul style="list-style-type: none"> <li><b>RF On</b></li> <li><b>Level 0 dBm</b></li> <li><b>Phase Modulation</b> menu: <ul style="list-style-type: none"> <li><b>PhiM Source External</b></li> <li><b>PhiM Ext Coupling DC</b></li> <li><b>PhiM deviation: 5 rad</b></li> </ul> </li> </ul> </li> <li>➤ Setting on the signal generator: <p>The internal LF generator of the signal generator delivers the modulation signal to the external modulation input of the DUT. The level of the modulation signal is controlled by use of an AC voltmeter (Item 14 of Table 1-1 Measuring equipment and accessories).</p> <ul style="list-style-type: none"> <li>- LFGGen Voltage 1 V peak</li> <li>- State ON</li> </ul> </li> <li>➤ Settings on R&amp;S FSQ: <ul style="list-style-type: none"> <li>FFT Demodulation</li> </ul> </li> <li>➤ Vary the signal generator frequency and measure the modulation depth.</li> <li>⇒ The modulation frequency response is the factor between the greatest and the smallest modulation depth.</li> </ul>
Recommended settings	<ul style="list-style-type: none"> <li>➤ LF in logarithmic steps, 3 steps per decade (1, 2, 5) from 10 Hz to 100 kHz</li> <li>➤ Perform the measurement for test frequency 23 MHz</li> <li>➤ Repeat the measurement with changing the settings to <b>PhiM Ext Coupling AC</b> for test frequency 23 MHz.</li> <li>➤ Repeat the measurement with changing the settings to <b>PhiM Ext Coupling AC</b> for test frequencies: 200.1 MHz, 266 MHz, 333 MHz, 400 MHz. LF sweep from 1 kHz to 100 kHz</li> <li>➤ Repeat the measurement with changing the settings to <b>PhiM Source Internal</b> <b>PhiM deviation 5 rad</b> at test frequency 400 MHz. LF sweep from 1 kHz to 100 kHz</li> </ul>

## Pulse Modulation

### ON/OFF Ratio

Test equipment	<ul style="list-style-type: none"> <li>- Spectrum analyzer (<a href="#">Table 1-1</a>, item 18)</li> <li>- Pulse generator (<a href="#">Table 1-1</a>, item 13)</li> </ul>
Test setup	<ul style="list-style-type: none"> <li>➤ To determine the ON/OFF ratio, connect the spectrum analyzer to the RF output socket of the DUT and let the PULSE EXT input open.</li> </ul>
Measurement	<ul style="list-style-type: none"> <li>➤ Setting on DUT: <ul style="list-style-type: none"> <li><b>RF On</b></li> <li><b>Level</b> 0 dBm</li> <li><b>Frequency</b> recommended test frequencies</li> <li><b>Pulse Modulation</b> menu: <ul style="list-style-type: none"> <li><b>Source External</b></li> <li><b>State On</b></li> <li><b>Polarity Inverse</b></li> </ul> </li> </ul> </li> <li>➤ Setting on Analyzer <ul style="list-style-type: none"> <li><b>FREQ/CENTER</b> test frequency</li> <li><b>SPAN</b> 0 Hz</li> <li><b>AMPT/REF LEVEL</b> 0 dBm</li> <li><b>BW</b> ⇒ <b>RES BW MANUAL</b> 3 kHz</li> <li><b>SWEEP</b> ⇒ <b>SWEEP TIME MANUAL</b> 100 ms</li> <li><b>MEAS</b> ⇒ <b>TIME DOM POWER</b> on</li> </ul> </li> <li>➤ Determine the output level of the DUT at the recommended test frequencies with <ul style="list-style-type: none"> <li><b>Pulse Modulation</b> ⇒ <b>Polarity Inverse</b></li> <li>and</li> <li><b>Pulse Modulation</b> ⇒ <b>Polarity Normal</b>.</li> </ul> <ul style="list-style-type: none"> <li>⇒ The level difference between the output level with Polarity Inverse and Polarity Normal is the ON/OFF ratio.</li> </ul> </li> </ul>
Recommended test frequencies	5 MHz, 150 MHz, 400 MHz, 1.1 GHz, 2.2 GHz, 3 GHz, 3.2 GHz

## Rise/ Fall Time

Test assembly	Test Assembly for Pulse Modulation (see page 1.3)
Test method	The RF signal is down converted to 0 Hz in phase. Thus, the IF output reproduces the RF amplitude vs. time.
Measurement	<ul style="list-style-type: none"> <li>➤ Setting on pulse generator: For adjustment statically high level, for measurement square wave pulse sequence with a frequency of 0.5 MHz, TTL level</li> <li>➤ Setting on DUT: <b>RF On</b> <b>Level</b> 0 dBm <b>Frequency</b> recommended test frequencies <b>Pulse Modulation</b> menu: <b>State On</b></li> <li>➤ Setting on Signal Generator: <b>RF On</b> <b>Level</b> Recommended Lo-Level of Mixer <b>Frequency</b> same as DUT</li> <li>➤ Setting on oscilloscope: Adjust V/div according to the mixer in use Time base 20 ns/div Trigger: - for adjustment free running, - for measurement 50 % of signal amplitude, rising and falling edge.</li> <li>➤ Adjustment: At each test frequency adjust phase using menu <b>RF Mod / Frequency/Phase / Phase Settings</b>. Vary the <b>Delta Phase</b> to obtain maximal signal output at the mixers IF port. The voltage at maximum corresponds to 100 % of RF amplitude.</li> <li>➤ Measurement: Evaluate the down converted pulse-modulated signal on the oscilloscope.</li> </ul> <p style="margin-left: 40px;">⇒ Rise time = time between 10% and 90% of signal amplitude Fall time = time between 90% and 10% of signal amplitude</p>
Recommended test frequencies	400 MHz, 1.1 GHz, 2.2 GHz, 3.2 GHz

### Video Crosstalk

Test assembly	As above for ON/OFF Ratio
Measurement	<ul style="list-style-type: none"> <li>➤ Setting on pulse generator: Square wave pulse sequence with a frequency of 100 kHz, TTL level</li> <li>➤ Setting on DUT: <b>RF On</b> <b>Frequency</b> 1 GHz, 6 GHz <b>Level</b> 0 dBm <b>Pulse Modulation State</b> On</li> <li>➤ Settings on the Analyzer <b>REF LEVEL</b> 0 dBm <b>FREQ CENTER</b> 100 kHz <b>SPAN</b> 10 kHz</li> <li>➤ Measure the signal level at 100 kHz with the analyzer. <ul style="list-style-type: none"> <li>⇒ The Video Crosstalk is the amplitude of the spectral line found at 100 kHz related to the RF carrier level</li> </ul> </li> </ul>

### Pulse Generator

#### PULSE VIDEO

Test equipment	- Storage oscilloscope ( <a href="#">Table 1-1</a> , item 3) with 50Ω Feed-through termination on input.
Test setup	➤ Connect the PULSE VIDEO socket on the rear of the DUT to the storage oscilloscope.
Measurement	<p>Setting on DUT:</p> <p><b>Pulse Modulation</b> menu: <b>State</b> On <b>Source:</b> Pulse Generator</p> <p><b>Pulse Generator</b> menu: <b>State</b> On <b>Pulse Period</b> 10 μs <b>Pulse Width</b> 5 μs</p> <ul style="list-style-type: none"> <li>➤ Setting on oscilloscope: 1 V/div Time base 2.5 μs/div Trigger: 50 % of amplitude, rising edge.</li> <li>➤ Check the signal for a symmetric square wave with 10 μs pulse period and 3 V 1.5 V amplitude. Rise and fall time &lt; 10 ns</li> </ul>





# Contents - Chapter 2 "Procedures after Module Replacement"

- 2 Procedures after Module Replacement.....2.1**
- Procedures after Replacing the Basis Board .....2.2**
- Adjustments .....2.2**
  - Internal Adjustments .....2.2
  - Adjustments of the Complete Unit.....2.2
  - External Adjustments Requiring Measurement Equipment .....2.2
  - External Level Correction .....2.3
  - Adjustment of internal Reference Frequency.....2.4
    - Recalibration .....2.4
- Internal Self Test.....2.4**



## 2 Procedures after Module Replacement

This chapter describes all necessary measures to restore the performance of the R&S SMC after module replacement.

There are no manual adjustments to be performed. Internal and external adjustment routines are implemented for this purpose.

Spare part RF boards are tested at Rohde & Schwarz with calibrated working standards according to the performance test. All measurement values are within the specified values including the measurement uncertainty as a minimum guard band. Power levels are corrected to nearly ideal values. When installing a spare part RF board the only difference at the RF side is the connecting cable between the RF board and the front panel. When testing the RF boards Rohde & Schwarz uses the same type of cable as it is installed in the R&S SMC.

OCXOs are tested at Rohde & Schwarz for the frequency adjustment range and the control voltage for an exact 10 MHz output frequency. This control voltage is coded in a digital value and stored on the OCXO module. In the R&S SMC the digital value is read from the OCXO module.

The probability that the R&S SMC meets its specifications after the replacement of a RF board and / or an OCXO is very high. To increase this probability even further and to detect a defective connecting cable between the RF board and the front panel Rohde & Schwarz recommends to adjust and to verify the power level and the reference frequency according to the instructions in the table below

If a calibration of the instrument is strictly necessary the performance test should be performed completely.

After replacing an assembly, check the following table to see which service procedure you perform.

Changed module	Required adjustment/correction	Recommended Test Procedure (refer to chapter 1 Performance Test "Checking the rated characteristics")
Basis Board	Setup/Internal Adjustments/Adjust All	None
RF Board	Setup/Internal Adjustments/Adjust All External Level Correction (power meter and special measuring software required)	Level Data at 0 dBm
OCXO	Setup/Internal Adjustments/Adjust All	Reference Frequency "Output of Internal Reference"
Power Supply	Setup/Internal Adjustments/Adjust All	None

## Procedures after Replacing the Basis Board

### Required equipment

USB Memory Stick (at least 128 MB)

### Required software:

Actual SMC\_Firmware see R&S homepage [www.rohde-schwarz.com](http://www.rohde-schwarz.com)

Copy the firmware to the root folder of the memory stick.

### Install the new Firmware

See Chapter 4 "Software Update".

## Adjustments

### Preliminary Remark

**Setting a defined initial state** by pressing the **PRESET** key prior to adjustments is recommended. To ensure that the internal adjustments are valid at operating temperature, at least **20 minutes warm-up time** at this temperature must be observed.

## Internal Adjustments

All internal adjustments are available in the **Setup/Internal Adjustments** menu (see operating manual).

## Adjustments of the Complete Unit

Performing **Setup/Internal Adjustments/Adjust All** activates all internal adjustments in a reasonable order.

The external adjustments have to be performed, if the recommended calibration interval is exhausted or the RF Board has been replaced.

## External Adjustments Requiring Measurement Equipment

The external adjustments require calibrated equipment and special software. Data sheet specifications of the unit are concerned. If required, contact your local Rohde & Schwarz representative.

## External Level Correction

External level correction measures output power over frequency and level and stores the correction values inside the instrument to maintain level accuracy. The R&S SMC provides a build in measuring procedure for external level correction.

### NOTICE

#### Risk of damage to the power sensor

Power sensor NRP-Z91 can be damaged when being exposed to R&S SMCs maximum output power. So it is recommendet to PRESET the instrument before connecting the power sensor. The build-in level correction procedure does not overload the sensor.

## Recalibration

Test equipment

- R&S NRP-Z91 or R&S NRP-Z92 power sensor with NRP-Z3 or NRP-Z4 USB adaptor

Test setup

- Power on instrument
- Setting on instrument:

#### PRESET

Setup Menu

Reference Oscillator

Source INTERNAL

Protection

Protection Level 2 = 147946 ENTER

- Connect the power sensor to the RF plug and to the USB connector of the instrument.
- Allow the R&S SMC and the power sensor to warm up for at least 20 minutes

Adjustment

- Setting on instrument:

Setup Menu

Internal Adjustments

Adjust Ext Level...

ECEXUTE

Adjustment Data CUSTOM

Note that the R&S factory level correction data is not replaced by this procedure, instead an additional data set is created.

The active correction data set is selected by the setting "Adjustment data"

## Adjustment of internal Reference Frequency

The frequency accuracy of the synthesizer is determined (set to internal reference) by a 20 MHz VTCXO or when the Option R&S SMC-B1 is fitted with a highly stable OCXO that is set to a calibrated frequency standard at the R&S factory. This oscillator is subject to ageing and can be recalibrated.

### Recalibration

**Important:** Allow the DUT to warm up for at least 20 minutes before adjustment is executed

- |                |  |
|----------------|--|
| Test equipment | - External frequency counter (1 Hz to RF <sub>max</sub> , resolution 0.1 Hz)                 |
| Test setup     | ➤ Connect a calibrated external frequency counter to the reference output at the rear panel. |
| Adjustment     | ➤ Setting on DUT:  |
- PRESET**
- Setup Menu
- Protection
- Protection Level 2 = 147946 ENTER
- Setting on spectrum analyzer (external frequency counter):
- MKR SIGNAL COUNT**
- MKR / NEXT CNT RESOL 0.1 Hz**
- Adjust the TCXO/ OCXO Calibration Value (Setup - Reference Oscillator - Calibration Value) for an external frequency counter reading of 10 MHz, with minimal error.
- Press Write **value to Eeprom** to store the DAC value.

## Internal Self Test

After each module replacement, it is recommended to perform the internal self test (refer to chapter 3, "Troubleshooting with Internal Self Test"). The self test checks the instrument by measuring internal diagnostic points and verifies whether generator is operating properly.

If a self test failure occurs, check again whether all cables are properly connected. If the self test fails continuously, contact your local service center.

## Contents – Chapter 3 "Repair"

<b>3 Repair</b> .....	<b>3.1</b>
<b>Instrument Design and Function Description</b> .....	<b>3.1</b>
RF Board .....	3.2
Internal and external 10 MHz reference .....	3.2
TCXO 20 MHz crystal oscillator .....	3.2
RF Synthesizer/DDS .....	3.2
Harmonics filters .....	3.3
LF generator .....	3.3
Pulse generator and Pulse Modulator .....	3.3
Modulation matrix and AM/FM/φM modulator .....	3.3
AM modulators .....	3.3
Automatic Level control .....	3.3
Step Attenuator and reverse power protection .....	3.4
Supply voltage control and filtering .....	3.4
Power Supply Module .....	3.4
Basis Board .....	3.4
Fuses .....	3.4
Switching regulators .....	3.5
Controller .....	3.5
FPGA (SMB_COM) .....	3.5
Keyboard Controller .....	3.5
Diagnostic ADC .....	3.5
EEPROM .....	3.5
SIM Card .....	3.5
Temperature sensor .....	3.5
Fan Controller .....	3.5
<b>Troubleshooting</b> .....	<b>3.6</b>
Measuring Equipment and Accessories .....	3.6
Switch-On Problems .....	3.7
Switch-on .....	3.7
Switch-off .....	3.7
Problems with Booting .....	3.10
Keyboard and Rotary Knob Test .....	3.11
Troubleshooting with Internal Self Test .....	3.12
Troubleshooting with Internal Test Points .....	3.13
Troubleshooting with Internal Adjustments .....	3.15
Instrument Faults .....	3.16
Troubleshooting – Basis Board Module .....	3.20
Supply Voltages .....	3.20
Fuses .....	3.21
Troubleshooting – RF Board module .....	3.22
Supply Voltages .....	3.22
Control Signals .....	3.23
Internal Input and Output Signals .....	3.24
Error Messages Concerning the RF Board Module .....	3.24
Warnings Concerning the RF Board Module .....	3.24
Frequency Error .....	3.25
Troubleshooting – Reference Oscillator option R&S SMC-B1 .....	3.26
Input and Output Signals .....	3.26
Error Messages Concerning the Reference Oscillator Module .....	3.27
Frequency Error, Reference Oscillator Adjustment .....	3.27

<b>Module Replacement.....</b>	<b>3.28</b>
Required tools .....	3.28
Overview of the Modules.....	3.28
After replacing an assembly.....	3.29
Safety Instruction .....	3.30
Dismounting the tube .....	3.31
Mounting the tube .....	3.31
Replacing Fuse .....	3.32
Installing Fuse .....	3.32
Replacing the Front Unit (A300) .....	3.32
Removing the Front Unit A300 (1411.4602.02).....	3.32
Install the Front Unit A300 (1411.4602.02).....	3.34
Replacing the TFT Display (A330), Encoder Board (A310), Flex. Switch Board, Pushbutton Board Set and the key frame with pane and front corner plate .....	3.36
Removing the flex.switch Board, the Pushbutton-Set and the key frame with pane.....	3.37
Removing the TFT Display A330 and the Encoder Board A310 .....	3.37
Removing the front corner plate .....	3.40
Install the Flex.switch Board, the Pushbutton Set and the key frame with pane.....	3.41
Install the TFT Display A330 and the Encoder Board A310 .....	3.42
Install the front corner plate .....	3.44
Replacing the Power Supply A50 .....	3.45
Removing the Power Supply A 50 .....	3.45
Install the Power Supply A 50 .....	3.46
Replacing the Basis Board 2 (A100).....	3.47
Removing the Basis Board 2 .....	3.47
Installing the Basis Board 2 .....	3.48
Replacing the SIM Card A 110 .....	3.49
Replacing the RF-Board (A200).....	3.50
Removing the RF-Board .....	3.50
Installing the RF-Board .....	3.51
Replacing the Fan Unit (E1).....	3.53
Removing the Fan Unit (E1).....	3.53
Install the Fan Unit (E1) .....	3.53
Replacing the SMC – B1.....	3.54
Install the SMC – B1 .....	3.54
Remove the Reference Oscillator SMC-B1 .....	3.55



### 3 Repair

## Instrument Design and Function Description

A schematic of the signal generator's design is presented below as block diagram at module level

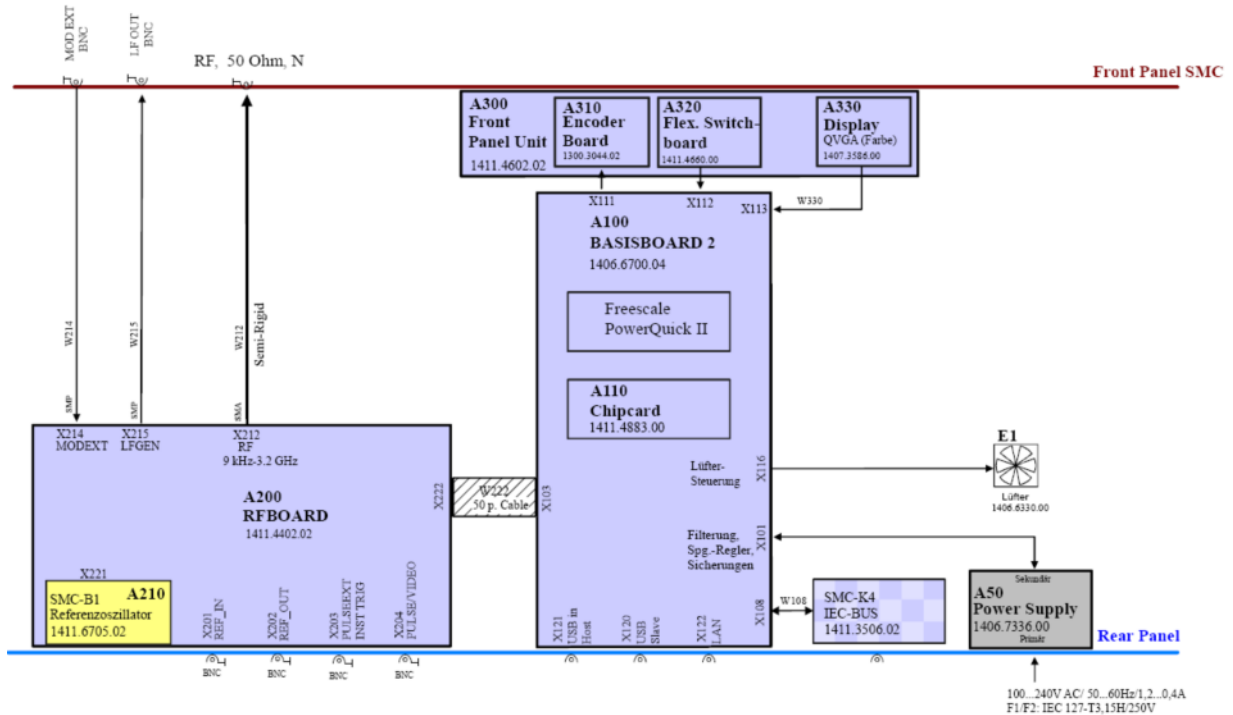

The R&S SMC consists of very few main modules and very few connections between these modules. The main units are:

- Power Supply
- Basis Board which includes all digital external Interfaces, the main CPU, the Fan control logic, the hardware drivers for the front panel and the Interface for the RF Board
- Front Unit consisting of the rotary knob with encoder, the flexible switch board and the QVGA Color Display
- RF Board including the whole measurement hardware
- R&S SMC-B1 Reference Oscillator which is plugged direct into the RF Board.

A detailed description of these modules is given in the next chapter.

## RF Board

The RF BOARD contains the complete measuring hardware of the instrument. The RF and LF signals are generated and modulated on the module. The output level is controlled by a level control loop controlling the level before the step attenuator. The fully electronic step attenuator is temperature compensated to achieve very precise output levelling of the instrument. The RF Board is equipped with a reverse power protection to ensure the instrument not being damaged due to supplying reverse power to the RF output of the instrument. The module is controlled by the Basis Board via a serial bus and few additional control signals.

### Implemented functions:

- Reference crystal oscillator and reference frequency switch
- Synthesizer
- LF generator
- Pulse generator and Pulse modulator control
- Modulation matrix and DDS with AM/FM/PhiM modulator
- AM modulator
- Harmonics filters
- Pulse modulator
- RF amplifiers
- Level control
- Step Attenuator
- Reverse power protection
- Diagnostics

## Internal and external 10 MHz reference

The instrument's reference frequency is determined either by the built-in TCXO, the optionally built-in OCXO (option R&S B1), or by an external 10 MHz reference signal that is fed to the input X201 REFIN. The output X202 REFOUT provides a buffered 10 MHz signal, which has been derived from the active reference source.

## TCXO 20 MHz crystal oscillator

In Reference internal mode without OCXO (Option R&S B1) the 20 MHz TCXO is the internal reference signal for the Synthesizer and LF generator. In this mode, the frequency of the TCXO can be adjusted by a DAC. When the 10 MHz OCXO (Option R&S B1) is plugged into the RF Board or Reference external mode is chosen the 20 MHz TCXO is synchronized to the 10 MHz reference signal with a PLL.

In Reference internal mode without the OCXO the 10 MHz output signal for X202 REFOUT is derived from the internal 20 MHz TCXO by the means of a frequency divider. In Reference external mode or with OCXO fitted the 10 MHz reference signal is fed straightforward to the 10 MHz REFOUT connector X202.

## RF Synthesizer/DDS

The multiplied 20 MHz signal of TCXO provides the system clock for the DDS. The RF signals from DC to 23.4375 MHz are generated directly by the DDS. In this mode all the modulation is done fully digital. The modulated signal is converted to the analog domain by a DAC. The analog RF signal is amplified low pass filtered and fed to the input of the step attenuator.

For frequencies above 23.4375 MHz the DDS generates a reference signal for the frequency synthesizer providing the fine frequency resolution for the frequency synthesis. In the synthesizer a VCO is locked to the reference frequency from the DDS. The RF signal is then generated by the means of fixed frequency dividers set to the appropriate divider ratio.

## Harmonics filters

The output signal of the frequency dividers is a square wave signal. To reach the guaranteed harmonic performance (see datasheet) the harmonics of the RF signal have to be suppressed. Due to the wide RF frequency range multiple filters are needed. The different filters are selected according to the RF output frequency and their cut off frequency. They are put into the RF signal path by the means of RF switches.

## LF generator

A DDS generates the LF sine wave signal. This signal can be used as a source for internal modulation or as output signal at LFOUT BNC connector for frequencies up to 100 kHz. The output amplitude of the LF signal is set with a multiplying DAC in the range from 10 mV to 2.55 V.

## Pulse generator and Pulse Modulator

The pulse generator is digitally implemented in an FPGA. The pulse generator has three different modes. The pulse generator can run free, can be triggered or gated externally using the PULSE EXT input. The input impedance at the PULSE EXT BNC connector is fixed to high-impedance. The pulse signal serves as a source for internal pulse modulation and can additionally be applied at the output PULSE VIDEO in a buffered way.

Below 23.4375 MHz the pulse modulator is implemented digitally switching on and of the output signal of the DAC. Above 23.4375 MHz three CMOS FET switches are used as pulse modulator.

## Modulation matrix and AM/FM/ $\phi$ M modulator

The external modulation signal from MODEXT can be AC- or DC-coupled. This signal is converted into the digital domain by the means of a 10 Bit ADC. The Frequency and Phase Modulations are implemented fully digital. For output frequencies below 23.4375 MHz the AM is implemented fully digital as well. For RF frequencies above 23.4375 MHz, the modulation signal is applied as reference signal to the level control loop. The AM modulation depth is set by a multiplying DAC. A switch matrix to select internal or external modulation signals is implemented in analog circuitry and additionally in the digital domain.

## AM modulators

Below 23.4375 MHz in the DDS RF frequency range the AM is generated digitally. For RF frequencies above 23.4375 MHz a PIN modulator is used.

## Automatic Level control

A RF detector at the output of the power amplifier is used to obtain information about the actual output power. This information signal is fed back to the Automatic Level Control (ALC) unit. The ALC sets the Level Control Voltage controlling the AM modulator to reach the desired output level.

## Step Attenuator and reverse power protection

Due to the limited dynamic range of the ALC RF detector the regulated RF signal is attenuated with passive attenuators. The step attenuator is a settable attenuator with known attenuation.

At the RF output of the RF Board a reverse power protection circuitry detects RF power fed into the RF Board from outside the instrument. To protect the R&S SMC against damage a relay disconnects the RF output, when excessive reverse power is detected. In standby or power off mode this relay is also in off state to protect the RF output of the instrument against damage.

## Supply voltage control and filtering

The module supply voltages are filtered by means of passive filtering and additional active voltage regulators. Linear regulators with very good noise and distortion suppression characteristics have been implemented based on operational amplifier circuitry.

## Power Supply Module

The power supply module provides all currents necessary for the operation of the signal generator. It can be switched on and off by means of the power switch on the rear panel. After switch-on, the instrument is either in standby or in operating mode, depending on a value stored in an internal EEPROM.

The power supply works over a wide input voltage range from 100 V to 240 V ( $\pm 10\%$ ) and AC supply frequencies from 50 Hz to 60 Hz ( $\pm 5\%$ ). The power factor correction meets EN 61000-3-2.

On the secondary side, the power supply generates three DC voltages (+5.0 V, +13.25 V, -13.25 V) and one standby voltage (+5 V), all  $\pm 5\%$ .

The control signal POWER\_ON\_N controlled by the front panel controller (depending on the operating key STBY on the front of the instrument frame) switches the power supply from standby mode to operating mode. In standby operation, it only supplies a 5 V standby to supply the front panel controller and the STBY LED on the front panel.

The secondary voltages are open-circuit-proof and short-circuit-proof with respect to ground and each other.

The power inlet module contains two fuses. Replace these fuses only with type and rating specified on the rear panel. If the replaced fuse blows again, change the module.

Further fuses are fitted on the BASIS BOARD as a means of fire protection.

## Basis Board

The Basis Board of the signal generator involves the following components and modules:

### Fuses

Each supply voltage is fused with one or several fuses on the Basis Board.

## Switching regulators

Switching regulators for 1.2 V, 1.8 V, 3.3 V, 7 V and 28 V supply voltages: These supply voltages are generated by means of switching regulators.

## Controller

Central Controller of the R&S SMC including all memory devices and external interfaces.

## FPGA (SMB\_COM)

This FPGA performs data processing for the serial bus, which sends setting data to the modules. The SMB\_COM is configured via an SPI-Interface of the processor. The Display Controller and timer functions are also implemented in the SMB\_COM.

## Keyboard Controller

The keyboard controller notifies the processor about keyboard and spin wheel events. The keyboard controller switches on or off the power supply module and memorizes the power on state of the instrument when the main power is cut. This state is reconstituted on powering the instrument again.

## Diagnostic ADC

The diagnostic ADC is used for measuring the voltages in the unit. These voltages are used for internal adjustments and the ALC S&H mode of the R&S SMC. Additionally the failure diagnostic of the instrument is carried out by the use of ADC.

## EEPROM

The following data is stored here: Header line data of the board and service information.

## SIM Card

A SIM card is used for identification of the instrument (e.g. serial number).

## Temperature sensor

A temperature sensor mounted on the Basis Board monitors the temperature. If a defined temperature above the guaranteed maximum operating temperature is exceeded, the power supply is switched off. So the R&S SMC secures itself against damage due to overheating.

## Fan Controller

A Fan for cooling the RF modules is connected to the BASIS BOARD and directly controlled according to the temperature of the Basis Board. This is done independent of the controller.

# Troubleshooting

The purpose of these troubleshooting instructions is to help to trace down malfunctions to board level. The instrument can thus be made ready for use again by means of board replacement.

If error tracing doesn't show clear results, we recommend that you ship your instrument to our experts in the service centers (see address list) for module replacement and further error elimination. Some module replacements involve calibration procedures requiring calibrated equipment and appropriate software.

**CAUTION**



**Danger of shock hazard**

For module replacement, ensure that the instrument is switched off and disconnected from the power supply by removing the plug from the AC and DC power connector.

Read all safety instructions at the beginning of this manual carefully before module replacement!

**NOTICE**

**Risk of damage to the boards**

Be careful not to cause short circuits when measuring voltages at pins placed close together!

The following utilities are provided in the signal generator for easy diagnosis:

- Internal selftest
- Internal diagnosis test points
- Internal adjustments
- Info line with error messages and history of messages
- Internal keyboard test

**Note:** When problems occur, first check whether any connections (cables, plug-in connections of boards, etc) are damaged or wrongly connected.

## Measuring Equipment and Accessories

Item	Type of equipment	Specifications recommended	Equipment recommended	R&S order No.
1	DC voltmeter		R&S URE	0350.5315.02
2	Spectrum analyzer	Frequency range 0 to 7 GHz	R&S FSP	1164.4391.07
3	Adapting cable	1 m long SMP-to-SMA connection	-	1129.8259.00
4	Oscilloscope	100 MHz	Hameg HM504-2	

## Switch-On Problems

The yellow LED on the front panel, next to the ON/OFF Button is directly connected to the Standby Voltage of the power supply (via a resistor on the Basis Board) and is therefore a good indicator of the basic working of the power supply.

When the instrument is switched on, the following modules are involved:

- Power supply
- Basis Board
- Switching pad

To analyze switch-on and switch-off problems that occur with the R&S SMC, the interplay of the individual modules is summarized in the following.

### Switch-on

When the ON/OFF button on the front panel is pressed, the voltage of the ON/OFF testpoint at X112 (switching pad connector) goes low. In this case the Basis Board pulls the signal on pin 13 of X101 (power supply connector see [Fig. 3-4](#)) low, which in turn switches on the power supply. In case of a prior emergency shutdown (pressing the ON/OFF Button for more than 5 seconds) it may take a few seconds until this mechanism works again.

Within four seconds after switch-on, the CPU takes over the control of pin 13 of the power supply connector. If the green LED on the front panel lights up for only a short time (approx. five seconds) and then the orange standby LED lights up again, this means that the CPU is not booting properly. The cause may be a defective or overheated power supply or Basis Board.

### Switch-off

Besides pressing the power switch, the instrument can be switched off in three ways.

After briefly pressing the ON/OFF button on the front panel, the CPU performs a normal system shutdown and then powers off the power supply via pin 13 of the power supply connector.

Pressing and holding the button on the front panel for longer than five seconds leads to an emergency shutdown, which is controlled by special hardware on the Basis Board. In this case, no user data can be saved.

The instrument can also be switched off by means of the temperature monitoring circuit on the Basis Board. If the temperature sensor on the Basis Board detects an over temperature (e.g. in the event that a fan fails), the power supply is switched off via pin 13 of the power supply connector. It can only be switched on again, after cooling down.

• **Error: Instrument cannot be switched on.**

Action	Possible error causes and further steps
Check power-on switch on the rear. Check fuses on the rear. ↓	Power switch OFF: Switch on power supply.
Check yellow LED (standby). ↓	LED remains unlit: Measure standby voltage at pin1 X101 (see <a href="#">Fig. 3-1</a> ). Rated value: 4.75 V... 5.25 V No voltage: Check power cable from power supply. no/faulty voltage: change power supply Otherwise: Loose Flex Switchboard (in X112) or bad contacts

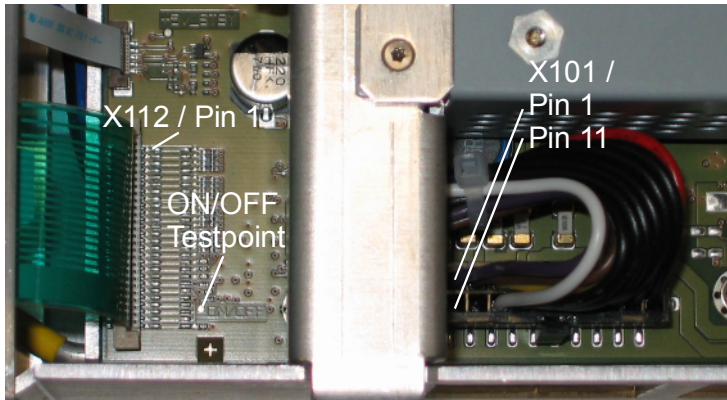

Fig. 3-1 ON/OFF Testpoint, X101 and X112 location on the Basis Board

• **Error: Signal generator starts up but display remains black**

Description of error	Possible error causes and further steps
CPU does not boot correctly	Check red LED on Basis Board (see <a href="#">Fig. 3-2</a> ). If LED does not turn red approx. 1 sec after power on, either the Basis Board FPGA does not configure correctly or the CPU does not boot: try to update the firmware, which includes the FPGA configuration data. If this does not help: Change Basis Board
Cables are loose	Check cabling between Basis Board and Display
TFT display defective	Replace Front panel with TFT display



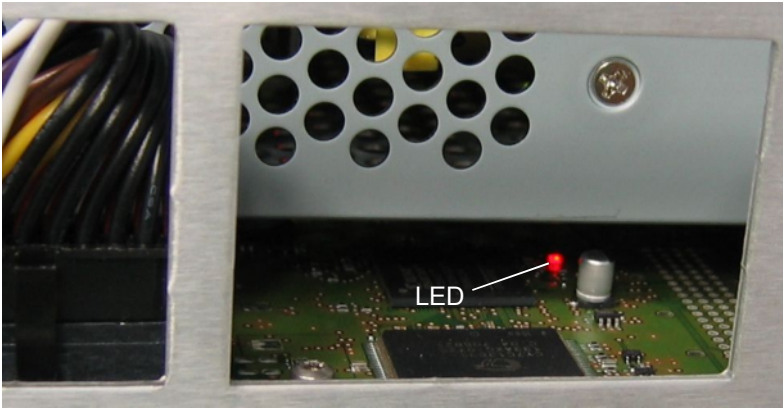

Fig. 3-2 Red LED location on the Basis Board

- **Error: Fan does not work**

Description of error	Possible error causes and further steps
Fan does not work	<p>Disconnect fan and check voltage on BASIS BOARD X116 (fan connector) between pin 1 and 2 (see <a href="#">Fig. 3-3</a>):            Rated voltage: 8 V ... 13 V, depending on temperature.</p> <p>Correct voltage: Replace fan</p> <p>Faulty voltage: Check the power supply of the Basis Board (see page 3.20).</p>

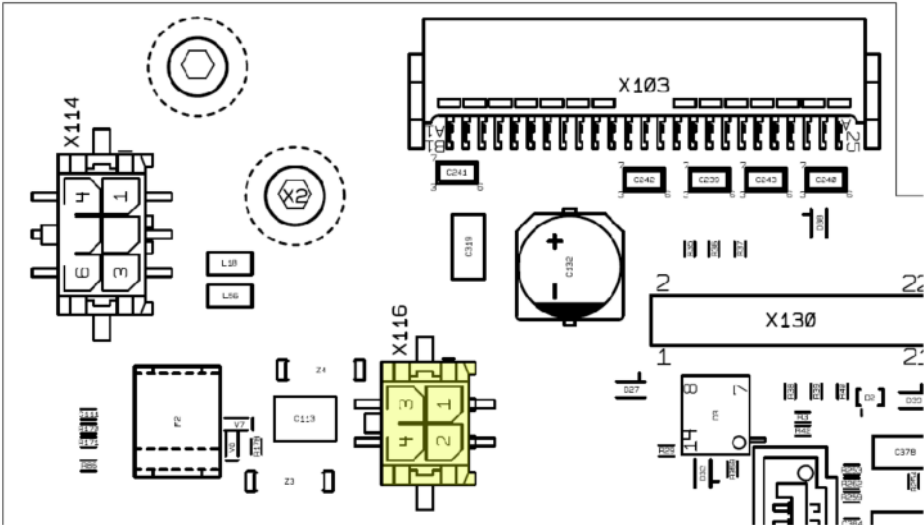



Fig. 3-3 X116 Fan Connector Pin Location

## Problems with Booting

- **Error: Unit does not start the application**

After switch-on, the signal generator first runs the Boot Loader. The Boot Loader displays the R&S Logo. The Boot Loader loads the FPGAs on the Basis Board and on the RF Board. After successful initialization of the computer (approx. 10 seconds), the LINUX operating system starts up and displays the background picture. Subsequently, the application is loaded. During loading, several progress bars are shown on the display.

All software of the R&S SMC is stored in an on board flash memory. There are no serviceable hardware parts related to mass memory. The only possible service action is the reinstallation of firmware, which requires at least some basically working computer and firmware.

Normal action	Error, possible causes and corrective action
<p>Start signal generator</p>	 <p>R&amp;S logo does not disappear</p> <p>Error: The operating system (LINUX) does not start.</p> <p>Try to reinstall the firmware with the help of the maintenance system. If this is not possible or does not solve the problem, replace the Basis Board.</p>

## Keyboard and Rotary Knob Test

- This **utility** allows you to check for proper operation of all front panel control elements

Normal action	Error, possible causes and corrective action
Test called with <b>SETUP</b> - Check Front Panel...	
An image of the front panel appears with gray keys. When a key is pressed once or the knob is moved, the field changes to green. If the key is pressed more than once, the field changes to red.	<hr/> <p><b>Note:</b> <i>Be careful with the rotary knob! Turn only slightly in the specified direction; otherwise the field will change to red.</i></p> <hr/>
When all operating elements including the rotary knob have been actuated once, all fields are green. If operating elements have been actuated twice, the fields are red.	If the color changes to red at the first actuation, a malfunction has occurred (bouncing). If the color of the corresponding field remains the same after actuation, the function is defective.  In either case:  Change the switching pad and/or rotary knob.
A message is output when all keys have been pressed: "All Front Panel Keys were accessed correctly"	<hr/> <p><b>Note:</b> <i>No error message is output even if a number of keys are red. The user must decide whether a malfunction has occurred.</i></p> <hr/>

## Troubleshooting with Internal Self Test

The internal selftest checks the instrument by measuring internal diagnostic points. **In case of an instrument fail this check should always be done first.**

Execute **SETUP** - **Selftest**. The selftest reports the modules failing the test:

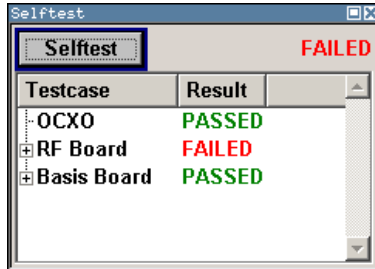

To see the details of the selftest select the board failing the selftest:

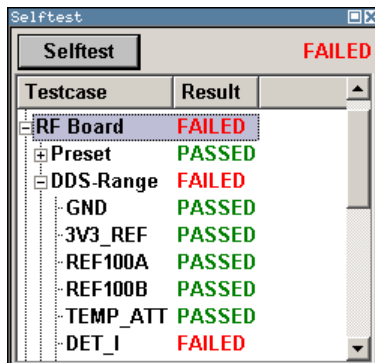

If the Basis Board fails this test check the fuses and supply voltages from the power supply (see page 3.20). When the Basis Board fails this test the other modules cannot work correct. So only if the Basis Board passes the selftest, check the other modules failing the selftest.

## Troubleshooting with Internal Test Points

The **Protection** menu provides access to the unlocking of protected service functions (authorized personnel of R&S Service Departments only). To deactivate the protection, the correct password has to be entered. After the instrument has been switched on, the protection levels 1 to 5 are automatically activated.

Protection Level 1 can be deactivated to expand the functionality of the internal adjustment, to change the host name and to access the test points. The password is 123456.



A diagnostic A/D converter on the Basis Board allows you to measure voltages at internal test points, which are located on all important modules of the instrument.

Diagnostic test points are located on following modules:

- Basis Board
- RFBOARD

The internal selftest checks all voltages at the points listed below, so if the selftest passes without a fail skip this manual test.

Normal action	Error, possible causes and corrective action
<p>Internal diagnosis switched on with:  <input type="button" value="SETUP"/> - Test Points...</p> <p>Select the desired test point under Select Test Point.</p> <p>To operate, set State ON</p>	
<p>The measured voltage is displayed under Voltage.</p> <p>"99.9999V" means that the test point does not exist.</p> <p>The diagnostic system operates with multiplexers on each board to switch the desired test point to the common line named DIAG on the Basis Board. Each test point is switched to the line only for the time of a measurement and switched off after it. The A/D converter is located on the Basis Board.</p> <p>It is advisable to begin by checking the test points on the Basis Board, since the diagnostic converter is located on this module.</p>	<p>For troubleshooting refer to the following chapters.</p> <p>Compare the displayed values with the values specified in the next table.</p> <p>Major deviations from the named values indicate a defect:</p> <p>Change the affected module.</p> <p>If all test points are out of tolerance, maybe only one of the modules is defective and disturbs the diagnostic system. To determine which module is defective, remove all modules that include test points one after another, except the Basis Board. If values are still out of tolerance, replace the Basis Board.</p> <p>If the remaining test points are in tolerance after removing a module the module removed is defective. Replace this board.</p>

Module	Test Point	Min	Max	Function
Basis Board	DIAG_SMB_BAB_ADCGRD	-25 mV	25 mV	Reference Ground
	DIAG_SMB_BAB_P7V	6.4 V	7.6 V	Supply Voltages
	DIAG_SMB_BAB_P5V	4.6 V	5.4 V	
	DIAG_SMB_BAB_P3V3	3.1 V	3.5 V	
	DIAG_SMB_BAB_P12V	12.2 V	14.3 V	
	DIAG_SMB_BAB_P0V9	0.88 V	0.92 V	
	DIAG_SMB_BAB_P28V	25.8 V	30.2 V	
	DIAG_SMB_BAB_P2V5	2.3 V	2.7 V	
	DIAG_SMB_BAB_P1V2	1.1 V	1.3 V	
	DIAG_SMB_BAB_M12V	-14.3 V	-12.2 V	
	DIAG_SMB_BAB_TEMP	0	75°C	
	DIAG_SMB_BAB_VREF	3.15 V	3.45 V	
	RF Board	DIAG_SMC_RF_GND	-100 mV	100 mV
DIAG_SMC_RF_REF3V3REF		3.15 V	3.45 V	Supply Voltage
DIAG_SMC_RF_REF100A		1.5 V	4.0 V	
DIAG_SMC_RF_REF100B		500 mV	2.0 V	
DIAG_SMC_RF_TEMP_ATT		-5°C	75°C	Temperature
DIAG_SMC_RF_DET_I		-50 mV	2.0 V	
DIAG_SMC_RF_VDETTUNE		-50 mV	5.1 V	
DIAG_SMC_RF_VCO_PLL		-50 mV	2.0 V	
DIAG_SMC_RF_VDET		-50 mV	8.0 V	
DIAG_SMC_RF_LEVELREF		-9.0 V	50 mV	
DIAG_SMC_RF_LCON		-1.5 V	11.0 V	
DIAG_SMC_RF_MODEXT		-1.05 V	1.05 V	Extern Modulation Input
DIAG_SMC_RF_TCXOCTRL		-50 mV	3.45 V	
DIAG_SMC_RF_PDDIVREF		-50 mV	3.45 V	
DIAG_SMC_RF_TCOMP		-50 mV	2.2 V	
DIAG_SMC_RF_2LOOPF		-3.0 V	28.0 V	

## Troubleshooting with Internal Adjustments

Various internal adjustments are necessary for correct operation of the instrument. The failure of a certain adjustment can shorten troubleshooting considerably. The affected module is the RF Board module.

**Note:** Failed internal adjustments can also be queried on the info page -> History.

Normal action	Error, possible causes and corrective action
<p>Internal adjustments call:  <input type="button" value="SETUP"/> - Internal Adjustments... - Adjust All            Internal adjustment of the RF Board is executed.</p>	<p>Abort during adjustment:</p> <p>The adjustments are all carried out exclusively on the RF Board, only the Diagnostic A/D converter on the Basis Board is needed. Check the Test Points on the Basis Board (see <a href="#">Troubleshooting with Internal Test Points</a>).</p> <p>If the Test Points on the Basis Board are in tolerance most probably the RF Board is defective. Check the RF Board being supplied correct (see page 3.22). If not in tolerance check the Basis Board (see <a href="#">Troubleshooting – Basis Board Module</a>).</p>

## Instrument Faults

The following table lists R&S SMC Faults. For every fault additional test are described to determine the defective module.

Fault	Test	Action if test fails
RF Output Level is wrong	R&S SMC settings: Instrument Preset Reference internal RF on Level = 8 dBm Measure the Output Level with a power meter across the frequency range. The difference between set and measured level has to be lower than guaranteed in the datasheet.	Check the mating torque of the SMA-connector at cable W 212 being 80 N cm to 110 N cm. Most probably the RF Board is defective. Check the RF Board being supplied correct (see page 3.22).
RF Output Frequency is wrong	R&S SMC settings: Instrument Preset Setup ➔ Adjustment ➔ "Adjust all" Setup ➔ Reference external RF on Level: 0 dBm Supply an external 10 MHz reference signal meeting the level and frequency specification given in the datasheet. Measure output frequency with a spectrum analyzer or a frequency counter synchronized to the same reference. The frequency error has to be < 0.1 Hz.	Most probably the RF Board is defective. Check the RF Board being supplied correct (see page 3.22).
	R&S SMC setting: Setup ➔ Reference internal Measure the 10 MHz reference output signal with spectrum analyzer or frequency counter and power meter. Output frequency and level have to meet the specifications given in the data sheet.	Without Reference Oscillator B1 being equipped most probably the RF Board is defective. Check the RF Board being supplied correct (see page 3.22). If the R&S SMC is equipped with Reference Oscillator R&S SMC-B1 remove the unit and perform this test again. If it works most probably the Reference Oscillator B1 is defective Check the Reference Oscillator being supplied correct (see page 3.26).



Fault	Test	Action if test fails
Poor Harmonic Distortion	<p>R&amp;S SMC settings:</p> <p>Instrument Preset</p> <p>Reference internal</p> <p>RF on</p> <p>ATT-Mode Auto</p> <p>Level = Maximum guaranteed level for harmonic distortion (see datasheet)</p> <p>Measure the level of the fundamental frequency with a spectrum analyzer. The level of every harmonic has to be at least 30 dB lower than the level at the fundamental frequency. Repeat this test over the frequency range of the instrument.</p> <p>Comment: In ATT-Mode fixed harmonic distortion is not guaranteed above Levels displayed under "Level" menu            ➔ "Attenuator Settings" ➔ "Fixed Range in".</p>	<p>Most probably the RF Board is defective. Check the RF Board being supplied correct (see page 3.22).</p>
Overvoltage protection does not trigger	<p>Switch on RF -&gt; apply a RF power of &gt;1 W to RF N connector -&gt; The overvoltage protection must trigger.</p>	<p>If RF output is not switched of the RF Board is defective.</p>
Slow Settling times	<p>Settling times are defined for GPIB remote control only. The settling time is the time-delay after asserting EO1 until level and frequency are within the given tolerance from their final values.</p> <p>Be careful not to measure with an instrument drifting on its own due to applying the RF from the R&amp;S SMC.</p>	<p>Most probably the RF Board is defective. Check the RF Board being supplied correct (see page 3.22).</p>
10 MHz Reference Input faulty	<p>Check the 10 MHz reference signal fed into the R&amp;S SMC with a spectrum analyzer or frequency counter and power meter. If level and frequency of this signal is matching the specification in the datasheet set the R&amp;S SMC to:</p> <p>Instrument Preset</p> <p>Reference external</p> <p>RF on</p> <p>Frequency = 1 GHz</p> <p>Level = 0 dBm</p> <p>Check for error Messages. No "External Reference Errors" are allowed to occur.</p> <p>Measure output frequency with a spectrum analyzer or a frequency counter synchronized to the same reference. The frequency error has to be &lt; 0.1 Hz.</p>	<p>Most probably the RF Board is defective. Check the RF Board being supplied correct (see page 3.22).</p>

Fault	Test	Action if test fails
10 MHz Reference Output faulty	<p>R&amp;S SMC setting: Setup ➔ Reference internal</p> <p>Measure 10 MHz reference output signal with spectrum analyzer or frequency counter and power meter. Output frequency and level have to meet the specifications given in the data sheet.</p>	<p><i>R&amp;S SMC without Reference Oscillator R&amp;S SMB-B1:</i></p> <p>Most probably the RF Board is defective. Check the RF Board being supplied correct (see page 3.22).</p> <p><i>R&amp;S SMC with Reference Oscillator R&amp;S SMC-B1:</i></p> <p>Remove the Reference Oscillator B1 (see perform this test again. If still failing most probably the RF Board is defective. Check the RF Board being supplied correct (see page 3.22).</p> <p>If the 10 MHz reference signal is in tolerance most probably the Reference Oscillator B1 is defective. Check this module being supplied correct (see page 3.26).</p>
LFGGen Output Faulty	<p>R&amp;S SMC settings: LFGGen Stat off</p> <p>Measure the input resistance of the LF signal output with a multimeter. The input resistance should be <math>10\ \Omega \pm 10\ \Omega</math>.</p> <hr/> <p>R&amp;S SMC settings: Setup ➔ Reference internal LFGGen Stat on LFGGen Level 1 V LFGGen Frequency 100 kHz</p> <p>Attention: LF specification applies to loads greater or equal <math>50\ \Omega</math> only!</p> <p>Check the level at the "LF"-BNC Connector with an oscilloscope or voltage meter. Check the frequency and harmonic distortion with an oscilloscope with FFT functionality or with a spectrum analyzer.</p>	<p>Check the connection of cable W215 to the RF Board (see <a href="#">Removing the RF-Board</a>).</p> <p>If it is connected correct most probably the RF Board is defective. Check the RF Board being supplied correct (see page 3.22).</p> <hr/> <p>Most probably the RF Board is defective. Check the RF Board being supplied correct (see page 3.22).</p>
MOD Ext Input Faulty	<p>Measure the input resistance of the Mod Ext BNC connector signal with a multimeter. The input resistance should be <math>221\ k\Omega \pm 20\ %</math></p>	<p>Check the connection of cable W214 to the RF Board (see <a href="#">Removing the RF-Board</a>).</p> <p>If connected correct most probably the RF Board is defective. Check the RF Board being supplied correct (see page 3.22).</p>

Fault	Test	Action if test fails
Amplitude Modulation Faulty	<p>The AM is specified only up to the Peak Envelope Power (PEP) noted in the datasheet. The PEP value of an AM signal with depth m at setting level P is</p> $P_{PEP} = \text{Level} + 20 \log_{10}(1 + m/100)$ <p>So at m = 100 % the PEP is 6.02 dB higher than the setting level shown in the display.</p> <p>The AM performance has to match the values given in the datasheet. Measure with a true demodulating receiver, i.e. a R&amp;S FSMR or R&amp;S FSL/ FSP/ FSU/ FSQ spectrum analyzer equipped with option R&amp;S K7</p>	Most probably the RF Board is defective. Check the RF Board being supplied correct (see page 3.22).
Frequency/ Phase Modulation Faulty	<p>FM and PhiM Modulation are generated in the DDS synthesizer reference signal on the RF Board. Run Internal Adjustments to ensure the VCOs generating the RF signal working in their optimum.</p> <p>The FM performance has to match the values given in the datasheet. Measure with a true demodulating receiver, i.e. a R&amp;S FSMR or R&amp;S FSL/ FSP/ FSU/ FSQ spectrum analyzer equipped with option R&amp;S-K7</p>	Most probably the RF Board is defective. Check the RF Board being supplied correct (see page 3.22).
Pulse Generator/ Pulse Modulator Faulty	The pulse generator is implemented fully digital in the RF Board FPGA. The pulse signals are fed exclusive on the RF Board to the pulse modulator switch. All external pulse-BNC connectors are fitted on the RF Board as well.	Most probably the RF Board is defective. Check the RF Board being supplied correct (see page 3.22).
Faulty Remote interface IEEE488, USB or LAN	All remote interfaces including the interface connectors are fitted directly on the Basis Board.	Most probably the Basis Board is defective. Check the Basis Board being supplied correct (see page 3.20).

# Troubleshooting – Basis Board Module

## Supply Voltages

Before Troubleshooting on the Basis Board switch the R&S SMC on and measure the supply voltages on its power supply connector (X101, see Fig. 3-4) and compare them to the values specified in the table below. Pin 13 is the Power On-Signal for the power supply. As long as the voltage at this pin is +5 V the power supply is switched off. The power supply is turned on by assigning 0 V to this pin. If one or more voltages are not of the required level, the power supply is defective.

Pin at X101	Test Point	Fuse	R&S SMC in stand by mode	R&S SMC switched On
5...10	+5V (1)	F4	0 V	+4.7 V ... +5.3 V
5...10	+5V (2)	F7	0 V	+4.7 V ... +5.3 V
3, 4	+13V2 (1)	F3	0 V	+12.4 V ... +14.2 V
3, 4	+13V2 (2)	F5	0 V	+12.4 V ... +14.2 V
2	-13V2	F6	0 V	-14.2 V ... -12.4 V
1	+5V_STBY	F9	+4.7 V ... +5.3 V	+4.7 V ... +5.3 V
13			> +3 V	< 0.8 V
14...20			GND	GND
	+28V		0 V	+25.8V ... 30.2V
	+7V		0 V	+6.4V ... +7.6V
	+3V3		0 V	+3.1V ... +3.5V
	+3V0		0 V	+2.85V ... +3.15V
	+2V5		0 V	+2.3V ... +2.7V
	+1V8		0 V	+1.7V ... +1.9V
	+1V2		0 V	+1.15V ... +1.25V

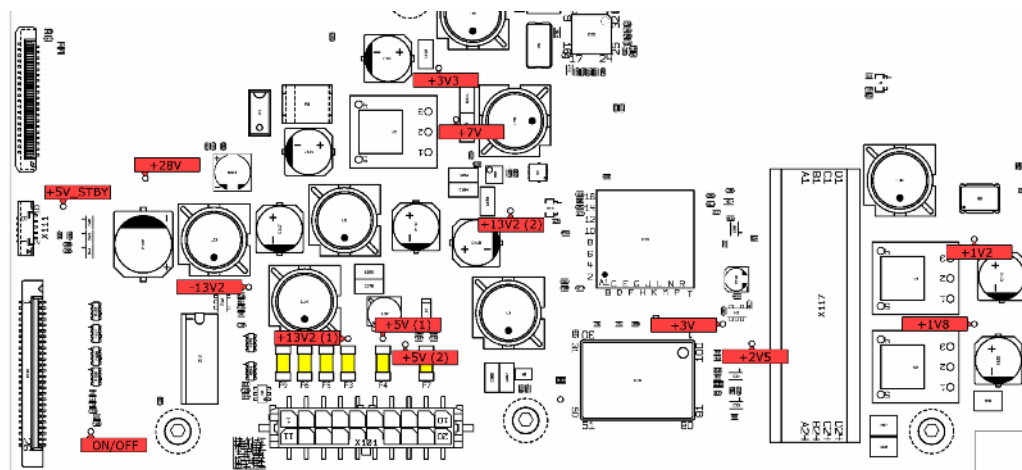

Fig. 3-4 Power Supply Test Points of the Basis Board

## Fuses

Switch on the R&S SMC and measure the voltage drop across the fuses F3 – F7 (yellow marked see [Fig. 3-4](#)) with a multimeter. The voltage across every fuse should be in the range -100 mV ... +100 mV. The fuses might be blown due to a defective module other than the Basis Board. If one of the fuses is blown replace the fuse with the correct type given below. Remove connection W222 to the RF Board and W113 to the display. Switch on the R&S SMC and check the voltage drop across the fuses after two minutes again. If one of the fuses is blown again the Basis Board is defective. If the fuses are OK switch of R&S SMC again and then connect the display and switch on the R&S SMC again. If one of the fuses is blown after two minutes and the display is not working the display is defective. If the RF Board is equipped with the Reference Oscillator B1 remove this unit first. Now repeat the fuse test by first adding the connection to the RF Board and then adding the Reference Oscillator B1. The module causing the blown fuse is defective.

Fuse	Type	R&S Part Number	Manufacturer Part Number
F3	T5A	1090.4442.00	Littlefuse R452.005 NRL (MRL)
F4	FF10A	6104.9199.00	Littlefuse R452.010 NRL (MRL)
F5	T5A	1090.4442.00	Littlefuse R452.005 NRL (MRL)
F6	T5A	1090.4442.00	Littlefuse R452.005 NRL (MRL)
F7	FF10A	6104.9199.00	Littlefuse R452.010 NRL (MRL)

## Troubleshooting – RF Board module

The tests listed below ensure that an assumed error on the RF Board module is not caused by a defective or incorrectly connected cable, incorrect adjustment or another module.

A comprehensive test of the module is to run the internal selftest and the internal adjustments. See chapters "Troubleshooting with Internal Self Test" (see page 3.12) and "Troubleshooting with Internal Adjustments" (see page 3.15).

### Supply Voltages

The supply voltages of the RF Board are inspected via the test points located on the bottom side of the RF Board nearby the ribbon cable connection (W222) to the Basis Board. Switch on the R&S SMC and measure the supply voltages of the RF Board at the test points shown in Fig. 3-5. The measured voltages have to meet the values given in the table below. If one or more voltages are not of the required level, check the Basis Board (see page 3.20).

PCB label	Test Point	R&S SMC switched On
	Shielding enclosure	GND
Q22	+12V	+12 V ... +14 V
Q23	+7V	+6.5 V ... +7.5 V
Q24	-12V	-14 V ... -12 V
Q25	+28V	+26 V ... + 30 V
Q26	+3V3	+3.1 V ... + 3.5 V

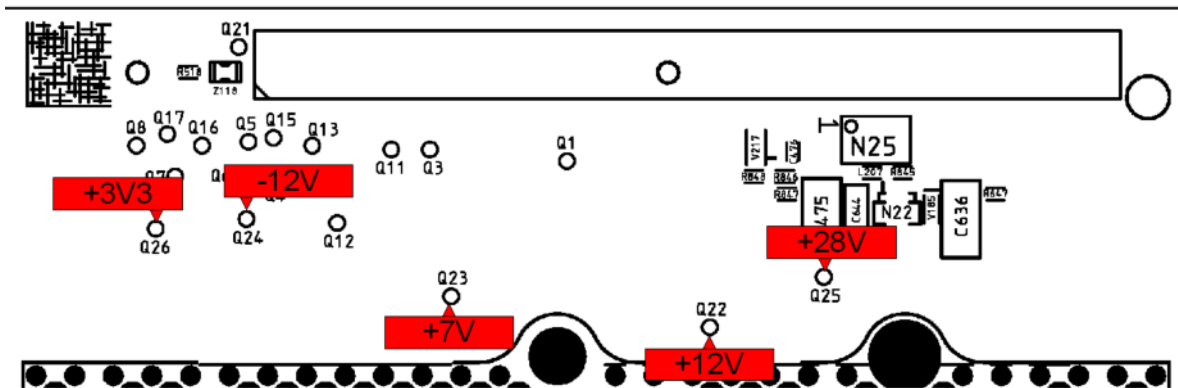

Fig. 3-5 Power Supply Test Points of the RF Board

## Control Signals

The control signals of the RF Board can be measured at test points on the bottom side of the RF Board nearby the ribbon cable connection (W222) to the Basis Board. (see Fig. 3-6). Signals going to the RF Board are colored red and signals coming from the RF Board are colored blue.

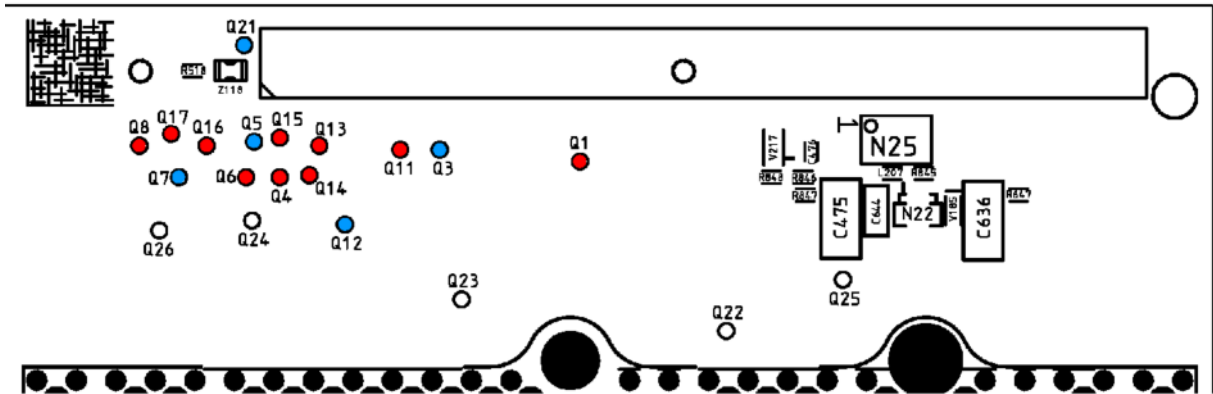

Fig. 3-6 Signal Test Points of the RF Board.

Perform the following settings at the R&S SMC:

- Preset
- RF on
- **SETUP** - **Protection...** (deactivate protection level 1, see 3.13) - **Test Point...** ⇒ **DIAG\_SMC\_RF\_LCON**

Use the test points in the table below and control the signals with an Oscilloscope.

Oscilloscope settings:

- Voltage: 1V / Div
- Timespan: 1 µs/ Div
- Trigger: Normal

Measure these signals

Test point	Function	Signal at normal operation	Defective
Q4, Q6, Q14, Q15	Logic Control Signals	Check the serial number of the RF Board displayed in the GUI: <b>SETUP</b> - <b>Hardware-Config...</b> - <b>RF Board</b> - <b>More...</b> If the number is correct these signals are OK. If not measure these Test-Points with an Oscilloscope: They should toggle between LOW and HIGH (LVC 3.3V)	Basis Board
Q5	Logic Control Signal		RF Board
Q11, Q13	Reset	HIGH (LVC 3.3V)	Basis Board
Q12	Interrupt Signal	normal Operation: HIGH (LVC 3.3V) Switch R&S SMC to Reference extern without applying 10 MHz Reference signal: LOW (LVC 3.3V)	RF Board
Q1	Blank Signal	normal Operation: LOW (LVC 3.3V) during Frequency switching: HIGH (LVC 3.3V)	Basis Board
Q3	Diagnosis Voltage	Voltage toggles on every update of the diagnosis	RF Board
Q8, Q16, Q17	Logic Control Signals	Check the serial number of the MOD-FPGA displayed in the GUI: <b>SETUP</b> - <b>Hardware-Config...</b> - <b>MOD-FPGA</b> - <b>More...</b> If the number is not 0.0 these signals are OK. If not measure these Test-Points with an Oscilloscope: They toggle between LOW and	Basis Board
Q7	Logic Control Signal		RF Board

		HIGH (LVC 3.3V) during the first seconds after switching on the instrument	
Q21	Interrupt Instrument Trigger	no signal at PULSE EXT / INST TRIG X203: HIGH (LVC 3.3V) trigger signal at PULSE EXT / INST TRIG X203: inverted trigger signal (LVC 3.3V)	RF Board

If one of these Signals is not as described change the connector cable and test again. If the signals still not match their description change the defective board according to the table.

## Internal Input and Output Signals

Connector, system	Signal name	Setting on signal generator	Frequency	Level	Signal flow
X212, SMA	RF	RF ON	9 kHz to 3.2 GHz	-120 dBm to + 19 dBm	to N RF connector at front
X214, SMP	MOD EXT	AM/FM/PM Source Ext	0.0 to 100 kHz	-1 V to +1 V	from BNC MOD EXT at front
X215, SMP	LFGEN	LF output on	0.1 Hz to 100 kHz	0 V to 2.55 V	to BNC LF at front

## Error Messages Concerning the RF Board Module

Error message	Error correction
"ALC unlocked"	<ul style="list-style-type: none"> <li>➤ Automatic Level Control ALC exceeds its upper bound.</li> <li>➤ Set attenuator mode "Auto".</li> </ul>
"main loop unlocked"	<ul style="list-style-type: none"> <li>➤ Execute Internal Adjustment "Adjust Synthesis".</li> <li>➤ If the error message does not disappear change the module.</li> </ul>
"Synthesis adjustment failed"	<ul style="list-style-type: none"> <li>➤ Execute Internal Adjustment "Adjust Synthesis".</li> <li>➤ If error messages does not disappear, check the diagnosis (see <a href="#">Troubleshooting with Internal Test Points</a>). If the diagnosis measurements work change the RF Board.</li> </ul>
"Synthesis adjustment data invalid"	<ul style="list-style-type: none"> <li>➤ Execute Internal Adjustment "Adjust Synthesis".</li> <li>➤ If the error messages does not disappear, check the diagnosis (see <a href="#">Troubleshooting with Internal Test Points</a>). If the diagnosis measurements work change the RF Board.</li> </ul>

## Warnings Concerning the RF Board Module

Warnings	Warning correction
"Extern reference oscillator out of range"	<ul style="list-style-type: none"> <li>➤ Check for correct External Reference Frequency setting and corresponding input signal.</li> <li>➤ If the input signal and frequency settings are correct and the error message is still displayed, change the module.</li> </ul>
"Output protection tripped"	<ul style="list-style-type: none"> <li>➤ Excessive reverse power at the RF port tripped the output protection.</li> <li>➤ Remove the overload condition and press the "RF ON/OFF" button to enter normal operation.</li> </ul>
"Pep value greater than defined limit"	<ul style="list-style-type: none"> <li>➤ The peak envelope power (PEP) is higher than the set upper limit.</li> </ul>



Warnings	Warning correction
	<ul style="list-style-type: none"> <li>➤ Reduce the output level.</li> </ul>
"Pep value less than defined lower bound (fix range)"	<ul style="list-style-type: none"> <li>➤ The peak envelope power (PEP) is lower than the permissible lower limit in the "fix range" mode of the attenuator.</li> <li>➤ Increase the output level, set the attenuator mode to "Auto", or reset the "fix range" by briefly switching the attenuator mode to "Auto" and then switching back to "Fixed".</li> </ul>
"Pep value greater than defined upper bound (fix range)"	<ul style="list-style-type: none"> <li>➤ The peak envelope power (PEP) is higher than the permissible upper limit in the "fix range" mode of the attenuator.</li> <li>➤ Reduce the output level, set the attenuator mode to "Auto", or reset the "fix range" by briefly switching the attenuator mode to "Auto" and then switching back to "Fixed".</li> </ul>
"Settings conflict, pep value vs. AM depth"	<ul style="list-style-type: none"> <li>➤ The peak envelope power (PEP) is higher than the permissible upper limit because of the set AM modulation depth.</li> <li>➤ Reduce the output level or increase the level limit (e.g. by switching the attenuator mode to "Auto" if "Normal" or "Fixed" mode was set). Reducing the AM modulation depth will also eliminate the warning.</li> </ul>
"Settings conflict, pep value greater than allowed level vs. frequency"	<ul style="list-style-type: none"> <li>➤ The full output level range cannot be utilized at low frequencies below 500 kHz because internal components may be overloaded. Reduce the output level to eliminate the warning.</li> </ul>
"Settings-conflict: frequency vs. deviation vs.modulation-mode"	<ul style="list-style-type: none"> <li>➤ The deviation setting in frequency or phase modulation is incorrect.</li> <li>➤ Check deviation setting of frequency or phase modulation.</li> </ul>
"settings for PulseGen are wrong"	<ul style="list-style-type: none"> <li>➤ Settings for the internal pulse generator are incorrect. Check the time settings of the pulse generator</li> </ul>

## Frequency Error

Error	Error correction
Internal reference frequency: Frequency error greater than limit given in datasheet	<ul style="list-style-type: none"> <li>➤ The frequency accuracy of the synthesizer is determined (set to internal reference, without option R&amp;S SMC-B1 OCXO) by a highly stable 20 MHz quartz oscillator that is set to a calibrated frequency standard at the R&amp;S factory. This oscillator is subject to ageing and can be recalibrated (see chapter 2 "Adjustment of internal Reference Frequency").</li> </ul> <p><b>Note:</b> <i>The internal reference can be impaired under the menu <b>Setup - Reference Oscillator - Adjustment</b>. This setting does not affect the factory adjustment and can be reset at any time by means of deactivation. If the tuning range is insufficient to reach the frequency error given in the <b>datasheet</b> the <b>TCXO is defective. Replace the RF Board.</b></i></p>

## Troubleshooting – Reference Oscillator option R&S SMC-B1

If a frequency error is observed which is greater than specified in the data sheet try to adjust the center frequency of the reference oscillator (see chapter 2 “Adjustment of internal Reference Frequency”). If it is not possible to meet the specifications by adjusting the center frequency the module is defective and should be replaced.

### Input and Output Signals

The Reference Oscillator has only one Futurbus connector (X1). The Reference Oscillator is plugged into the RF Board (X221 see Fig. 3-7). All signals and the supply voltage are fed to the module through this connector. Check the voltages for the OCXO being according to the following table. To test the serial bus signals watch the signal lines while toggling between internal and external reference with an Oscilloscope. Voltage Levels between LOW and HIGH (LVC 3.3V).

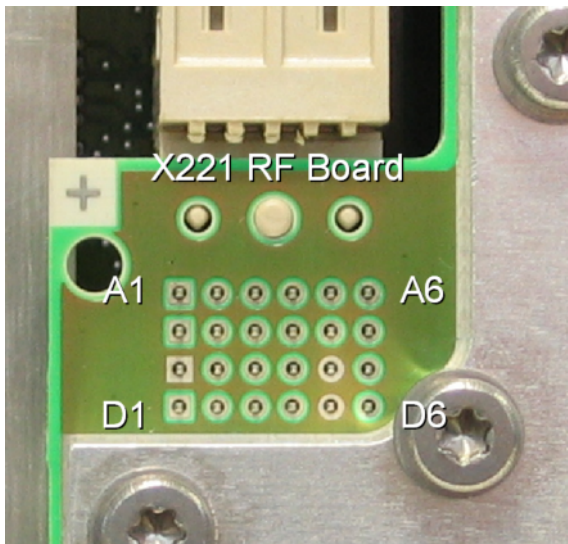

Fig. 3-7 Pin location X221 on RF Board

Pin of X221 RF Board	Voltage/Signal	Pin of X221 RF Board	Voltage/Signal	Pin of X221 RF Board	Voltage/Signal	Pin of X221 RF Board	Voltage/Signal
A1	Clock-signal serial Bus	B1	NC	C1	GND	D1	+4.5 V - +5.5 V
A2	Data-signal to B-1 serial Bus	B2	+ 3.3 V when Oven Cold	C2	NC	D2	0 V when B1 fitted
A3	Chip Select signal serial Bus	B3	Data-signal from B-1 serial Bus	C3	+5.0 V when B1 on	D3	10 MHz LVDS signal
A4	NC	B4	NC	C4	NC	D4	
A5	NC	B5	NC	C5	GND	D5	GND
A6	+4.5 V - +5.5 V	B6	+4.5 V - +5.5 V	C6	+10.5 V – +12.5 V	D6	NC

## Error Messages Concerning the Reference Oscillator Module

Error message	Error correction
<ul style="list-style-type: none"> <li>➤ "OCXO 10 MHz oven cold"</li> </ul>	<ul style="list-style-type: none"> <li>➤ If this message does not disappear after 10 minutes, OCXO is defective, change the module.</li> </ul>
<ul style="list-style-type: none"> <li>➤ "Synchronization error on internal reference"</li> </ul>	<ul style="list-style-type: none"> <li>➤ Switch the R&amp;S SMC to external Reference and supply a 10 MHz 10 dBm signal to the Reference Input of the RF BOARD. If the error disappears and the R&amp;S SMC is working correct the OCXO is defective, change the module.</li> </ul>
<ul style="list-style-type: none"> <li>➤ "OCXO: cannot read EEPROM data"</li> <li>➤ "OCXO: cannot store adjustment data"</li> </ul>	<ul style="list-style-type: none"> <li>➤ This indicates problems concerning the data transfer from and to the EEPROM of the module. If changing the module does not help, change the RF Board module.</li> </ul>

## Frequency Error, Reference Oscillator Adjustment

Error	Error correction
<p>Internal reference frequency: Frequency error greater than limit given in datasheet</p>	<ul style="list-style-type: none"> <li>➤ The frequency accuracy of the synthesizer is determined (set to internal reference) by a highly stable oven controlled 10 MHz quartz oscillator that is set to a calibrated frequency standard at the R&amp;S factory. This oscillator is subject to ageing and can be recalibrated (see chapter 2 "Adjustment of internal Reference Frequency").</li> </ul> <hr/> <p><b>Note:</b> <i>The internal reference can be tuned by up to approx. <math>\pm 10^{-6}</math> under the menu <b>Setup - Reference Oscillator - Adjustment</b>. This setting does not affect the factory adjustment and can be reset at any time by means of deactivation.</i></p> <hr/>

## Module Replacement

This section describes in detail the replacement of modules. Chapter 5 provides information on how to order spare parts; it contains the list of mechanical parts with order numbers and the illustrations for module replacement.

### Required tools

- Star screwdriver TX 20
- Star screwdriver TX 8
- Star screwdriver TX 6
  
- Side cutter
- Flat pliers
- Pincette
- Tubular box wrench or a combinations wrench 16mm
- Torque wrench 8mm

#### Notice

#### Urgent

*Please screw all the HF – conductions with the Torque wrench (60 Ncm) and NOT with an ordinary open-end wrench*

Please wear gloves, when you touch the electronic devices

## Overview of the Modules

Table 3-1 Overview - module replacement

Module	Designation	Order No.	See page
Power Supply (AC 90 V to 264 V)	A50	1406.7320.00	<a href="#">3.69</a>
Basis Board 2	A100	1406.6700.04	<a href="#">3.58</a>
RF Board	A200	1411.4402.02	<a href="#">3.66</a>
Front unit R&S SMC	A300	1411.4602.02	<a href="#">3.33</a>
Encoder Board	A310	1300.3044.02	<a href="#">3.43</a>
TFT 3.5 QVGA DRGB LED (Display 3.5 inch)	A30	1407.3586.00	<a href="#">3.37</a>
Fan Unit	E1	1406.6330.00	<a href="#">3.73</a>

**Note:** The words "left" and "right" in the manual always refer to the front view of the instrument.

## After replacing an assembly

After you have replaced one of the assemblies, certain adjustments, functional checks or performance tests have to be carried out. Please refer to chapter 2 “Procedures after module replacement”.

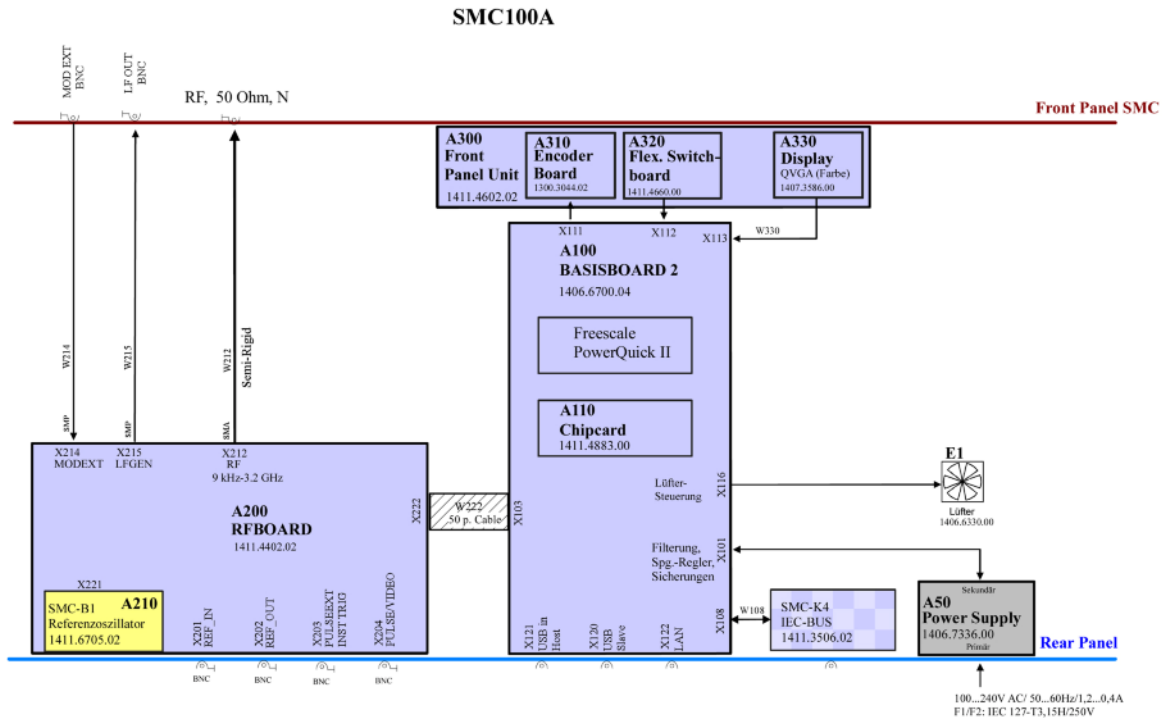

## Safety Instruction

### CAUTION Danger of injury



For module replacement, ensure that the instrument is switched off and disconnected from the power supply by removing the plug from the AC and DC power connector. Read all safety instructions at the beginning of this manual carefully before module replacement!  
Only Rohde & Schwarz Service personnel and trained personnel may perform a module replacement.

When removing the rear feet, the unit can slip out of the cabinet.

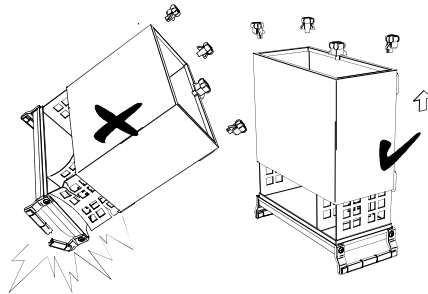

- Put the unit into the front handles, before removing the rear feet and taking off the cabinet. Thus the risk of personal injuries and damages to the unit is avoided.
- When mounting the cabinet take care not to pen in the fingers. Also pay attention not to damage or pull off cables. Screw the rear feet back on immediately after mounting the cabinet. Do not move the unit with the rear feet missing

### CAUTION Risk of damage to the electronic components



To avoid damage of electronic components the operational site must be protected against electrostatic discharge

The following two methods of ESD protection may be used together or separately:

- Wrist strap with cord to ground connection.
- Conductive floor mat and heel strap combination.

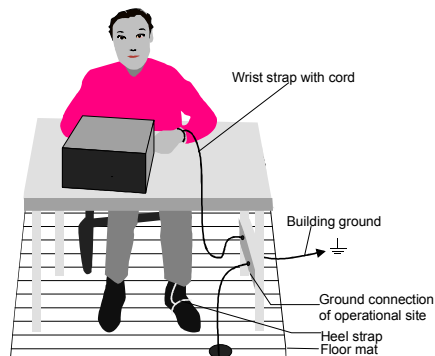

## Dismounting the tube

- Put the instrument on the protective front corners.
- Unscrew the four screws of the 2 protective rear corners (rear right 1096.6647.00 (550) and rear left 1096.6630.00 (540)) on both sides and take them off.
- Pull off the tube SMC100A 1411.4383.00 (510).

**When mounting the tube, take care not to damage or pull off cables!**

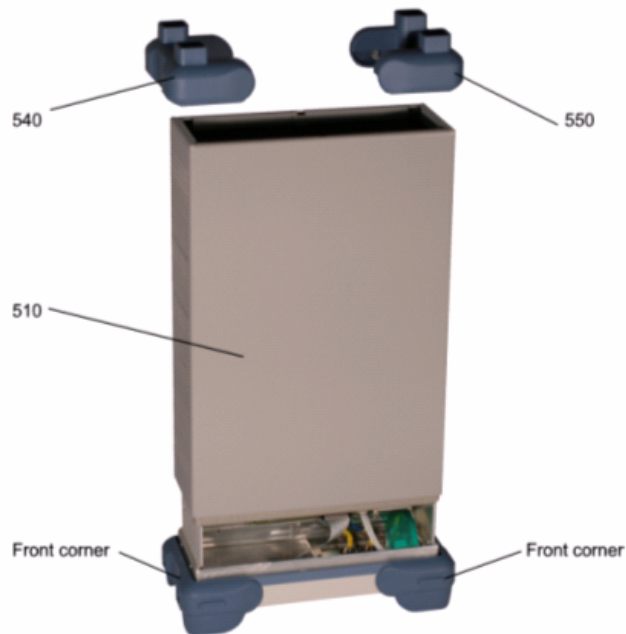

## Mounting the tube

*(See picture from "Dismounting the tube")*

- Put the instrument on the protective front corners.
- Pull on the tube SMC100A 1411.4383.00 (510).
- Put the two protective rear corners (rear right 1096.6647.00 (550) and rear left 1096.6630.00 (540)) on the SMC and screw it with the four screws.

**When mounting the case, take care not to damage or pull off cables!**

## Replacing Fuse

**NOTICE Risk of damage to the instrument**

Ensure that the power supply cord is disconnected.  
If you are not using the supplied spares, be sure to use fuses of the same type and rating.

- Switch off the instrument.
- Disconnect the power supply cord.
- To replace a fuse, unscrew the fuse holder at the rear panel of the instrument.

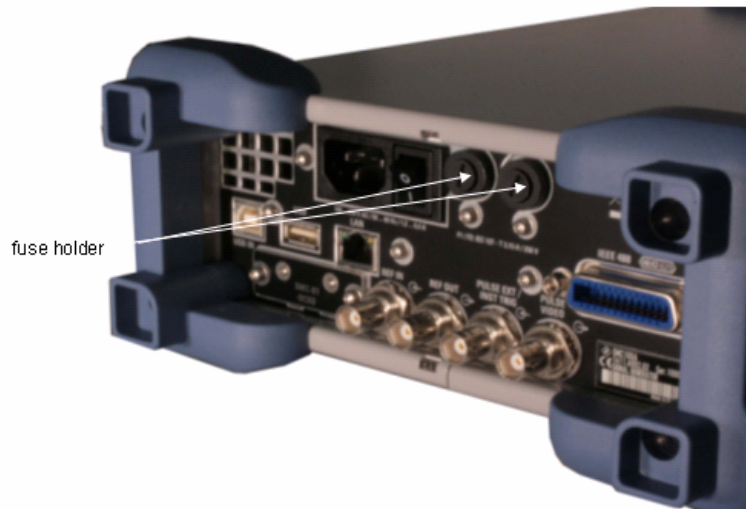

- Pull the fuse of the fuse holder.

## Installing Fuse

(see picture from "Replacing Fuses")

- Push in the fuse in the fuse holder ( Fuse 5 x 20 250V, 3,15A)
- Screw the fuse holder at the rear panel of the instrument.

## Replacing the Front Unit (A300)

(See drawings 1411.4602.01, 1411.4748.00 and 1411.4002.01).

### Removing the Front Unit A300 (1411.4602.02)

- Switch off the instrument and pull the mains plug.
- Dismounting the tube (see page 3.31).
- Disconnect the 4 screws, remove the protective corner front left and right 1096.6618.00 (520) and 1096.6624.00 (530) and the front cover SMC 1411.4683.00 (500).





SCREWS

- Disconnect the four screws 1148.3271.00 (401), two on the top side and two on the bottom side of the front unit A300 1411.4602.02 (400).

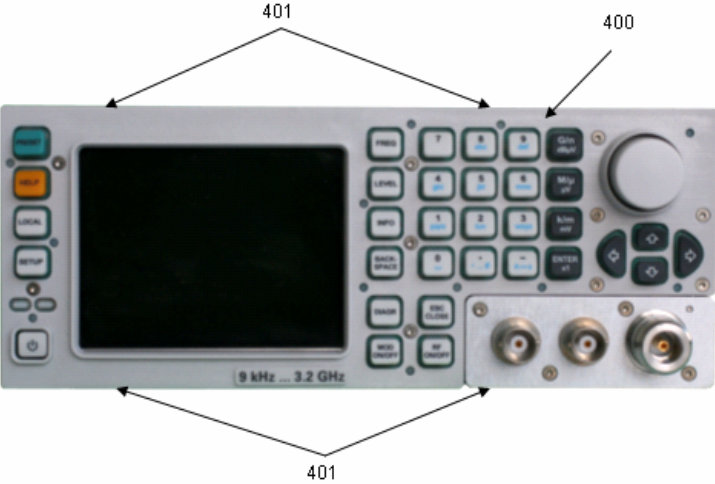

- Pull off the flex.switch board cable 1411.4660.00 (403) from X 112, the flex-strip cable W310 1146.9150.00 (413) from X111 and the flex-strip cable W330 1411.4731.00 (409) from X113 from the basisboard 2 A100 1406.6700.04 (150).

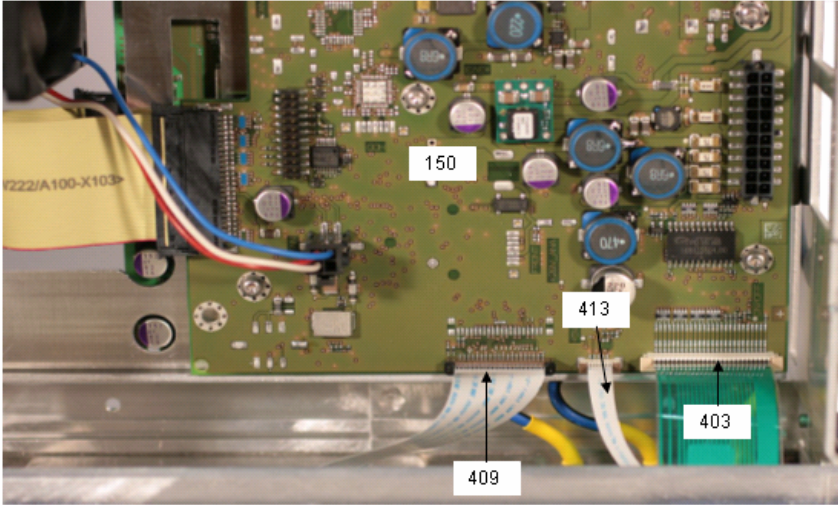

- Slice up the two cable ties 0015.9038.00 (208) and disconnect the cables W214 Mod Ext – RF Board 1406.8149.00 (650), the W215 LF- RF Board 1406.8132.00 (660) and W212 (630).

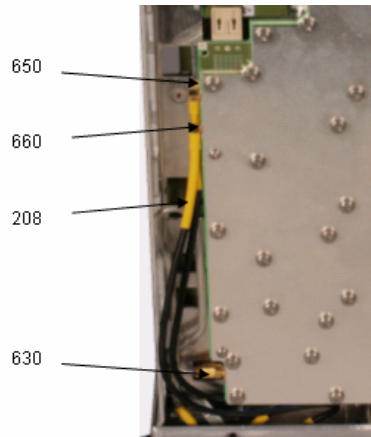

- Remove the front unit A300 1411.4602.02 (400) forwards.

### **Install the Front Unit A300 (1411.4602.02)**

- Move the Front Unit A300 1411.4602.02 (400) backwards.
- Connect the cables W214 Mod Ext – RF Board 1406.8149.00 (650), the W215 LF- RF Board 1406.8132.00 (660) and W212 (630) and fix them with the two cable ties 0015.9038.00 (208).

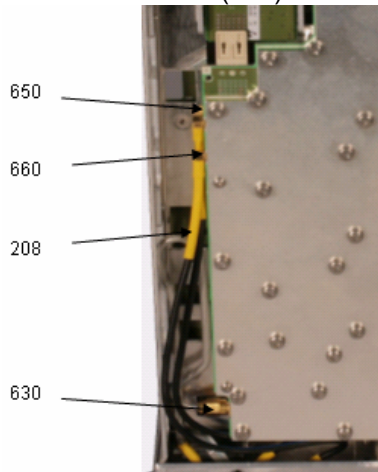

- Plug in the flex.switch board cable 1411.4660.00 (403) to X 112, the flex-strip cable W310 1146.9150.00 (413) to X111 and the flex-strip cable W330 1411.4731.00 (409) to X113 from the basisboard 2 A100 1406.6700.04 (150).

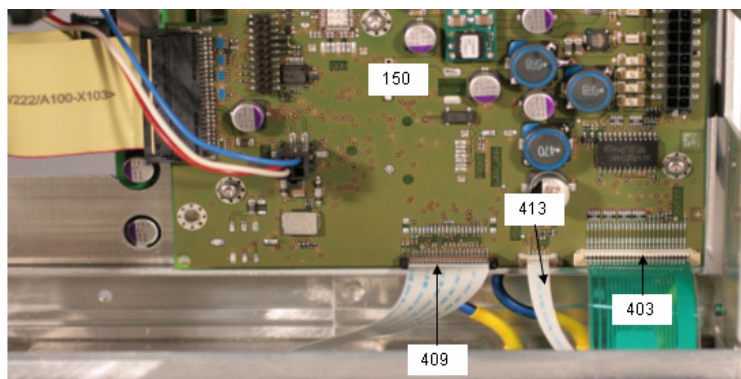

- Connect the four screws 1148.3271.00 (401), two on the top side and two on the bottom side of the front unit A300 1411.4602.02 (400).

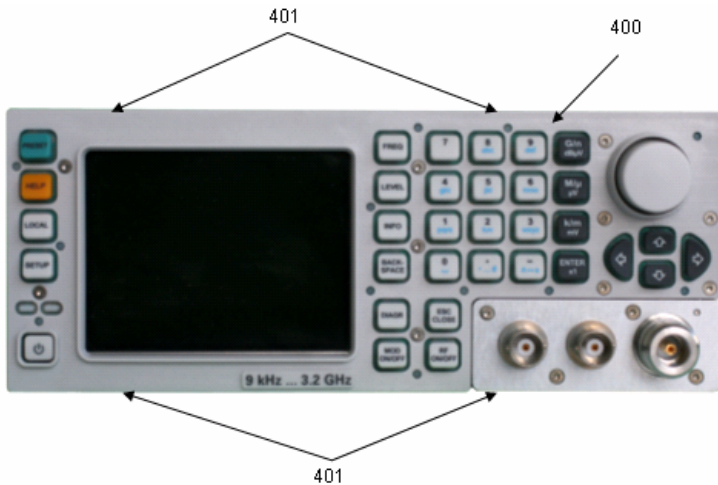

- Move the front cover SMC 1411.4683.00 (500) and the protective corner front left and right 1096.6618.00 (520) and 1096.6624.00 (530) back and screw it with the four screws.

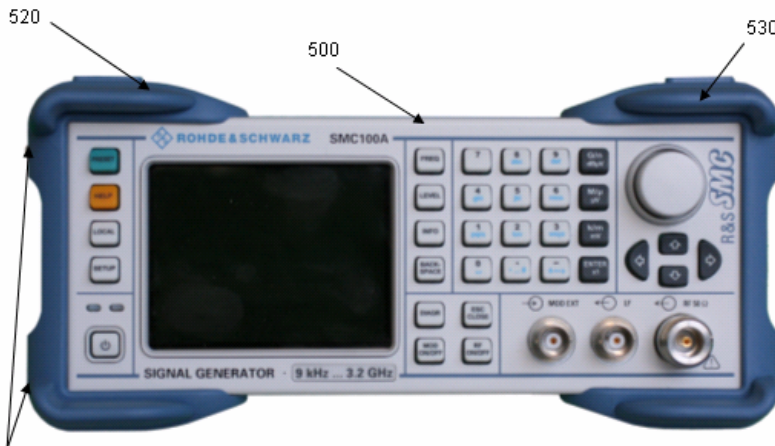

- Mounting the tube (see page 3.32).

**CAUTION**



**Store the RF cables at a save place.  
These cables are not components of the front unit.**

- Urgent
- Please screw all the HF – conductions with the Torque wrench and NOT
- with an ordinary open-end wrench

When you mount the cables, ensure their correct position in the front unit.

## Replacing the TFT Display (A330), Encoder Board (A310), Flex. Switch Board, Pushbutton Board Set and the key frame with pane and front corner plate

It is recommended to replace the front unit as a whole. Principally, it is possible to replace the individual components of the front unit (See drawing 1411.4602.01).

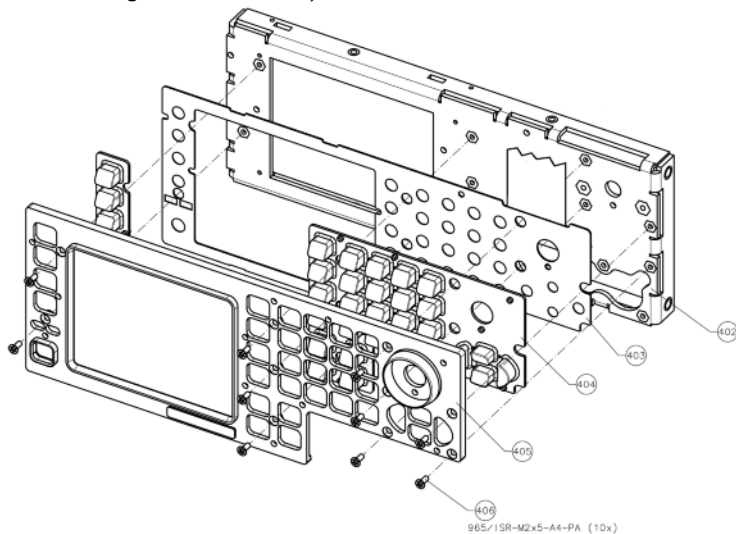
**NOTICE***Risk*

When installing the keyframe with pane (50), make sure it is free of dust and fingerprints.

## Removing the flex.switch Board, the Pushbutton-Set and the key frame with pane

- Removing the Front Unit A300 1411.4602.02 (400) (see page 3.34).
- Remove the Knob 21126131.00 (416) from the front side of the SMC.



- Unscrew the ten screws 1148.3265.00 (406) and remove the key frame with pane 1411.4754.00 (405), the push-button board SMC 1411.4654.00 (404), the flex.switch board 1411.4660.00 (403)

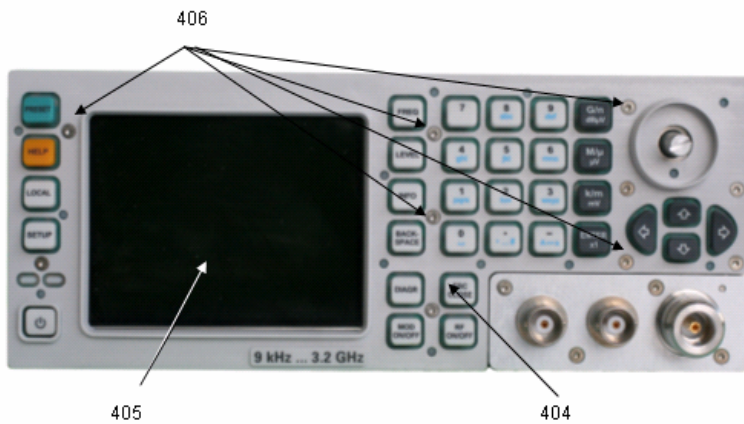

## Removing the TFT Display A330 and the Encoder Board A310

### NOTICE

### Risk

When installing the TFT Display, make sure it is free of dust and fingerprints.

- Removing the Front Unit A300 1411.4602.02 (400) (see page 3.34).
- Remove the Knob 21126131.00 (416) from the front side of the SMC.

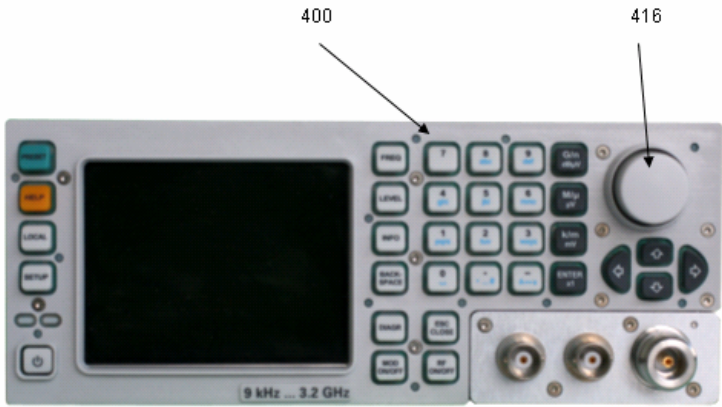

- Unscrew the two screws 1148.3059.00 (412) and remove the encoder board A310 1300.3044.02 (411).

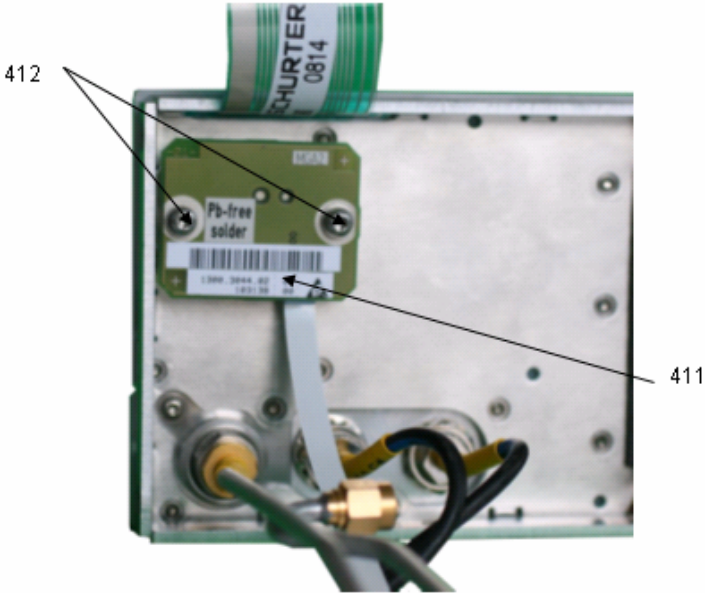

- Clip the display cover 1411.4631.00 (410) out of the mounting though 1411.4619.00 (402).

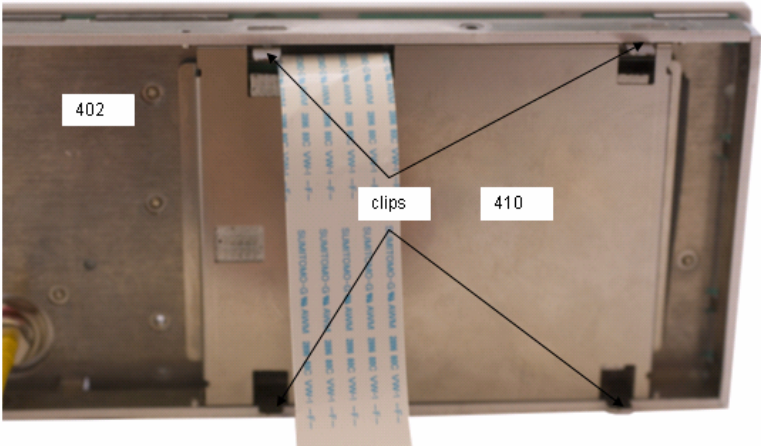

- Remove keyframe with pane , push-button boards and flexstrip.

- Clip out the display, with pressing down the clip and push carefully the display from frontside

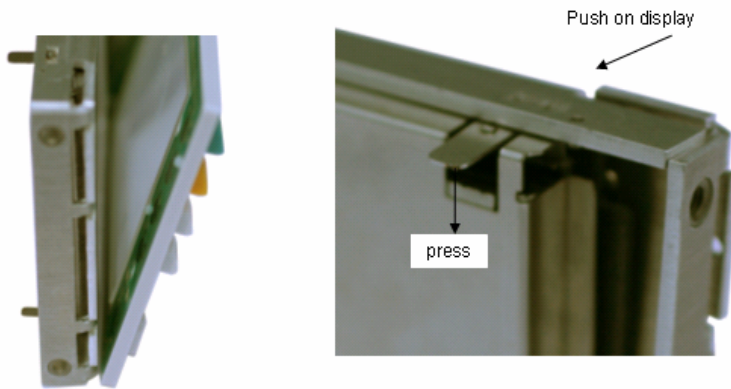

- Remove display A330 1407.3586.00 (408) from the display cover 1411.4631.00 (410)

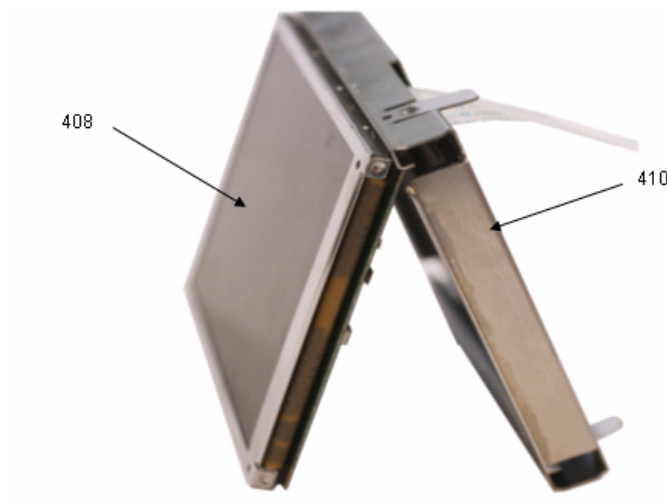

### Removing the front corner plate

- Dismounting the tube (see page 3.31).
- Slice up the two cable ties 0015.9038.00 (208) and disconnect the cables W214 Mod Ext – RF Board 1406.8149.00 (650), the W215 LF- RF Board 1406.8132.00 (660) and W212 (630).

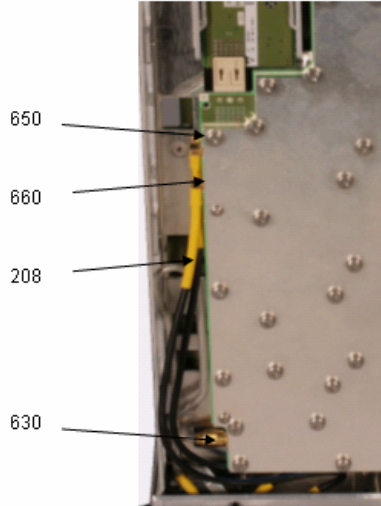

- Remove the Knob 21126131.00 (416) and the front cover SMC 1411.4302.00 (500) from the front side of the SMC.



- Unscrew the four screws 1148.3265.00 (415) and remove the front corner plate 1411.4748.00 (414) forwards.

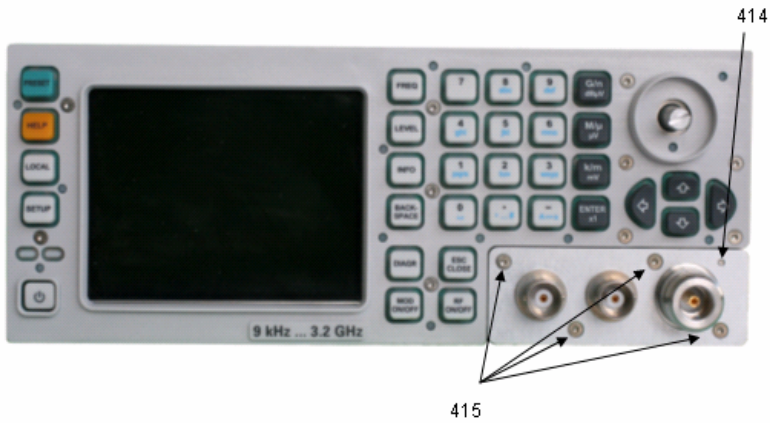



## Install the Flex.switch Board, the Pushbutton Set and the key frame with pane

- Move the key frame with pane 1411.4754.00 (405), the push-button board SMC 1411.4654.00 (40), the flex.switch board 1411.4660.00 (30) back and screw them with the ten screws 1148.3265.00 (406).

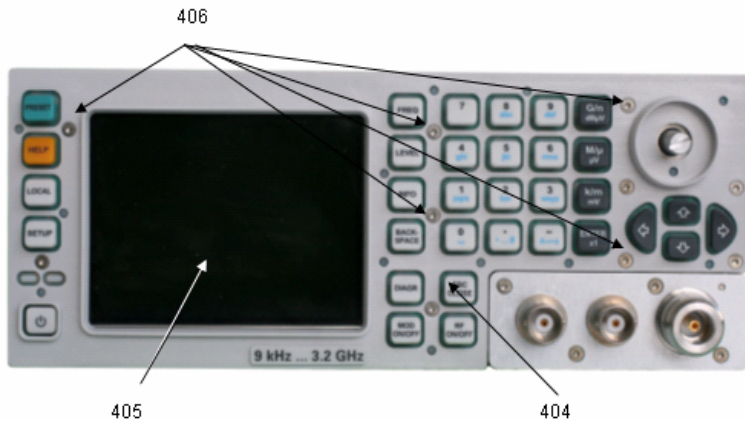

- Move the Knob 21126131.00 (416) on the front side of the SMC.



- Install the Front Unit A300 1411.4602.02 (400) (see page 3.34).

## Install the TFT Display A330 and the Encoder Board A310

**NOTICE Risk**

**When installing the display, make sure it is free of dust and fingerprints.**

- Move the TFT display 1407.3586.00 (408) into the display cover 1411.4631.00 (410).

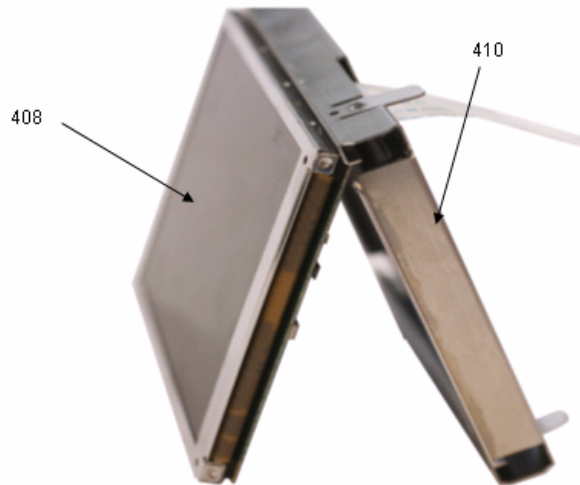

- Put in the powder seal 1411.4690.00 (407) in shown position. Use the position markers in in the mounting though 1411.4619.00 (402)

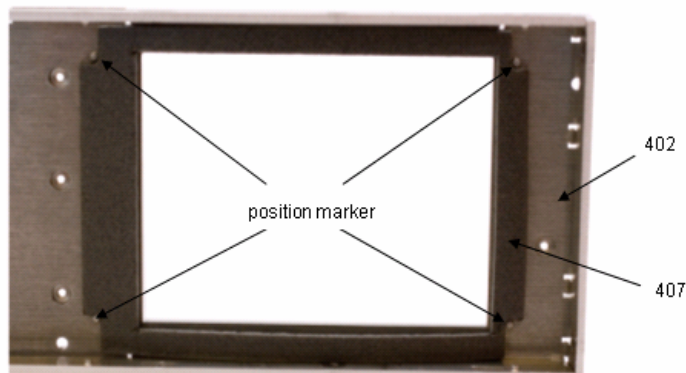

- Clip the display cover 1411.4631.00 (410) in the mounting through 1411.4619.00 (402). Place it like shown, then clip it in first on upper side, then on lower side.

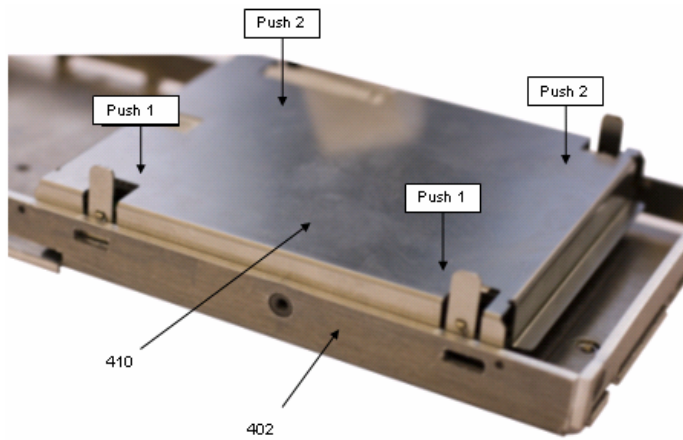

- Move the encoder board A310 1300.3044.02 (411) and screw it with the two screws 1148.3059.00 (412).

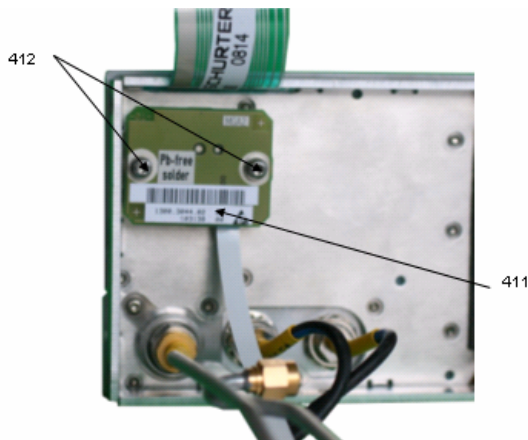

- Move the Knob 21126131.00 (416) on the front side of the SMC.



- Install the Front Unit A300 1411.4602.02 (400) (see page 3.34).

## Install the front corner plate

- Move the front corner plate 1411.4748.00 (414) backwards and screw it with the four screws 1148.3265.00 (415).

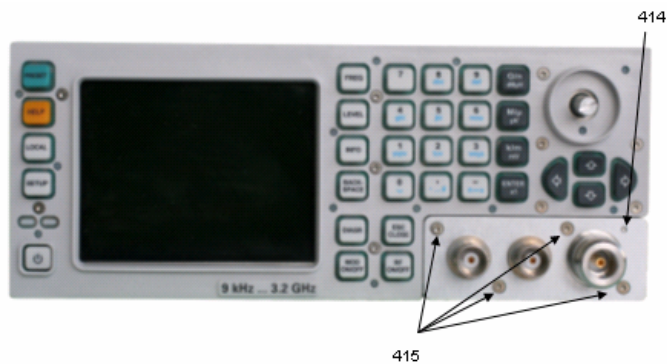

- Connect the cables W214 Mod Ext – RF Board 1406.8149.00 (650), the W215 LF- RF Board 1406.8132.00 (660) and W212 (630) and fix them with the two cable ties 0015.9038.00 (208).

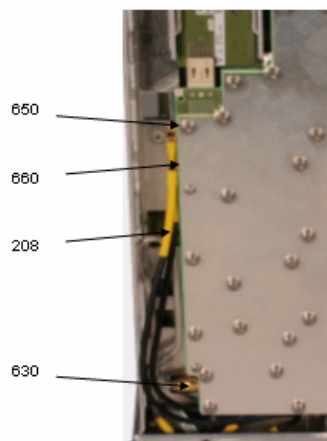

- Move the Knob 21126131.00 (416) and the front cover SMC 1411.4302.00 (500) to the front side of the SMC.

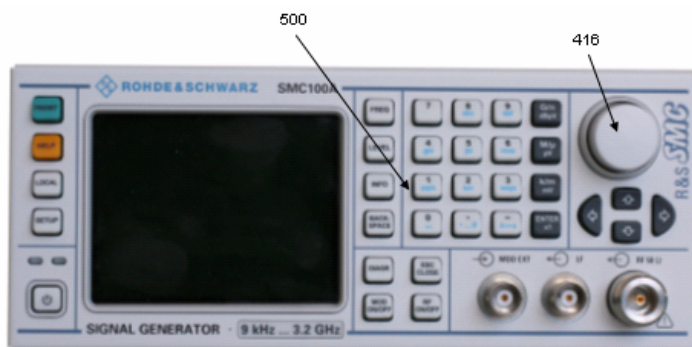

- Mounting the tube (see page 3.32).

## Replacing the Power Supply A50

(see drawing 1411.4002.01).

### Removing the Power Supply A 50

- Switch off the instrument and pull the mains plug.
- Dismounting the tube (see page 3.31).
- Disconnect the three combinations screws 0041.1653.00 (160) on the back side of the instrument.

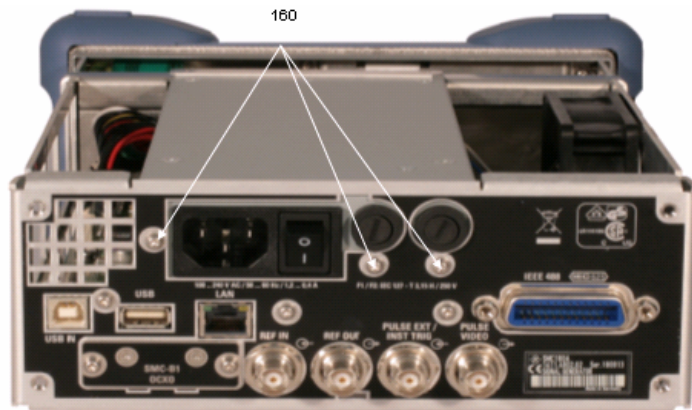

Disconnect the two screws 1148.3271.00 (206) from the power supply holder 1/2 1411.4277.00 (204)

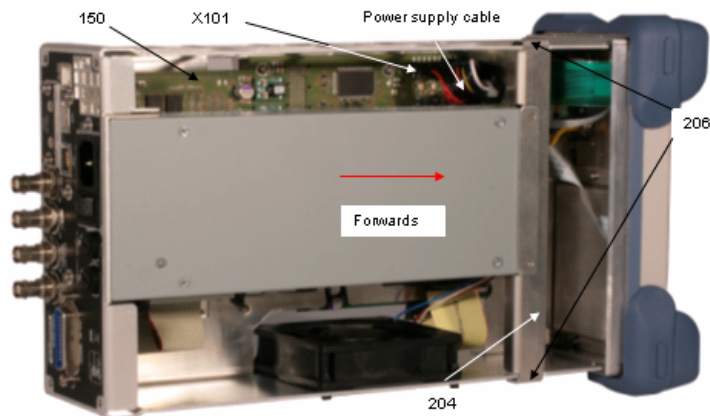

- Pull of the power supply cable from X 101 from the basis board 2 A100 1406.6700.04 (150).
- Pull the power supply forwards and remove it.

## Install the Power Supply A 50

- Move the power supply into the instrument and push it backwards.

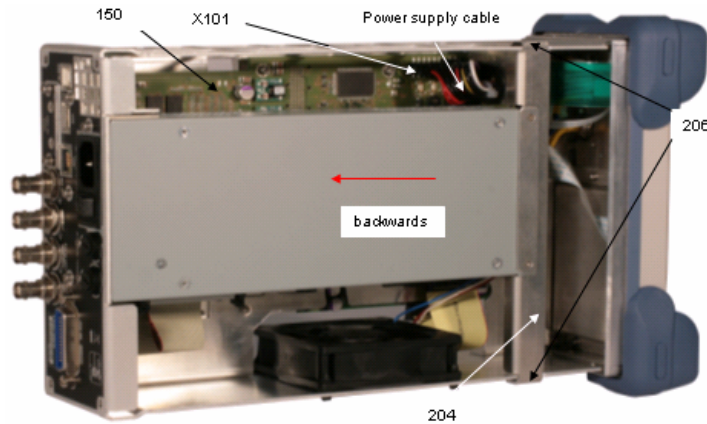

- Plug the power supply cable in X 101 from the basis board 2 A100 1406.6700.04 (150).
- Connect the power supply holder 1/2 1411.4277.00 (204) with the two screws 1148.3271.00 (206) on both sides of the instrument.
- Connect the three combinations screws 0041.1653.00 (160) on the back side of the instrument.
- Mounting the tube (see page 3.32).

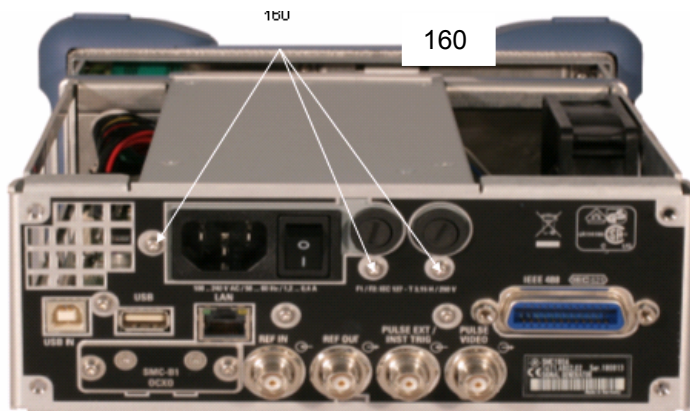

## Replacing the Basis Board 2 (A100)

(see chapter 5, drawing 1411.4002.01).

### Removing the Basis Board 2

- Switch off the instrument and pull the mains plug.
- Dismounting the tube (see page 3.31).
- Removing the power supply (see page 3.50).
- Unscrew the three combinations screws 0041.1653.00 (160) on the back side of the instrument.

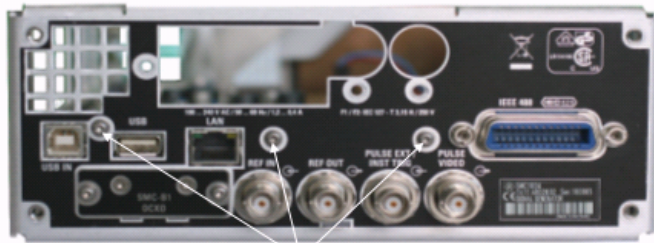

160

- Pull off the flex.switch board cable 1411.4660.00 (403) from X 112, the flex-strip cable W310 1146.9150.00 (413) from X111 and the flex-strip cable W330 1411.4731.00 (409) from X113.

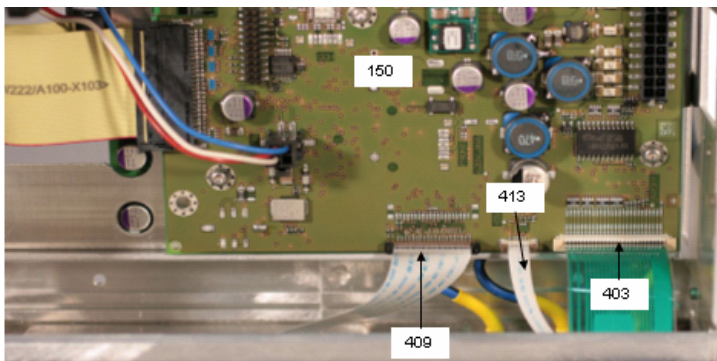

- Unscrew the six screws 0041.1653.00 (160) from the basis board 2 A100 1406.6700.04 (150).

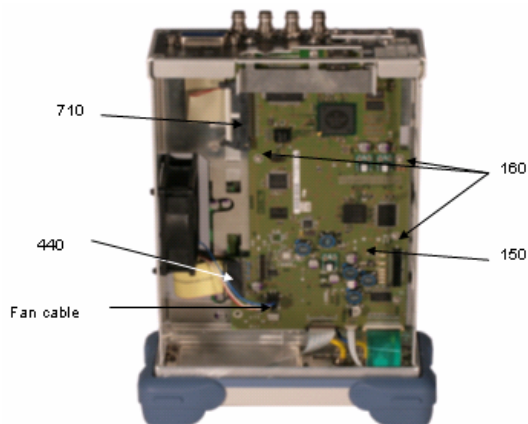

- Pull off the IEC Bus Cable W108 1411.4760.00 (710) from X108, the fan cable from X 116 and W222 cable BB-RF Board 1406.8110.00 (440) from X 103.
- Remove the basis board 2 A100 1406.6700.04 (150).

## Installing the Basis Board 2

- Move the basis board 2 A100 1406.6700.04 (150).
- Connect the IEC Bus Cable W108 1411.4760.00 (710) on X108, the fan cable on X 116 and W222 cable BB-RF Board 1406.8110.00 (440) on X 103.

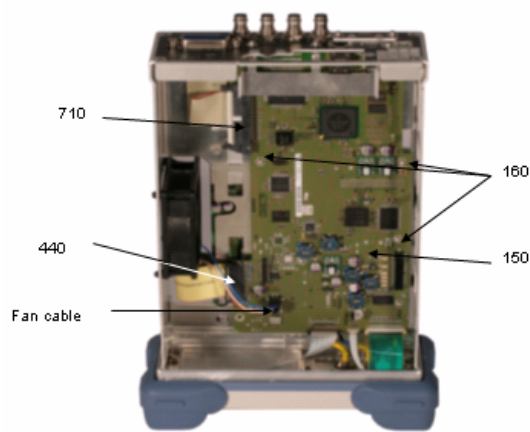

- Screw the six screws 0041.1653.00 (160) to the basis board 2 A100 1406.6700.04 (150).
- Connect the flex.switch board cable 1411.4660.00 (403) on X 112, the flex-strip cable W310 1146.9150.00 (413) on X111 and the flex-strip cable W330 1411.4731.00 (409) on X113.

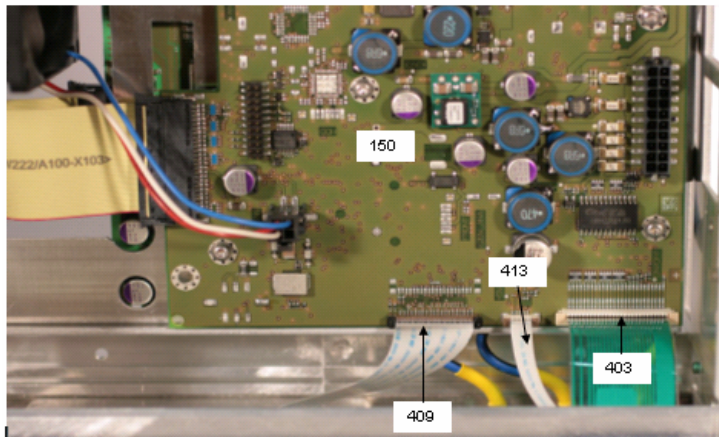

- Screw the three combinations screws 0041.1653.00 (160) on the back side of the instrument.

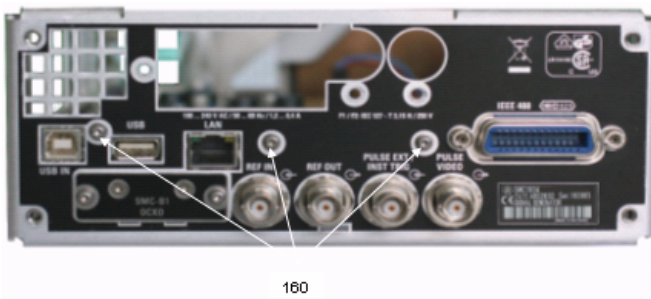

- Install the power supply (see page 3.51).
- Mounting the tube (see page 3.32).



## Replacing the SIM Card A 110

**NOTICE** When changing the Basis Board 2, you have to remove the SIM card.

The SIM card is part of your instrument and will not be replaced by Rohde & Schwarz if lost. Therefore, always keep the SIM card with you.

- Switch off the instrument and pull the mains plug.
- Dismounting the tube (see page 3.31).
- Removing the power supply (see page 3.50).
- Removing the Basis Board 2 (see 3.53).

The SIM card A110 1411.4883.00 (155) is located on the rear side of the Basis Board 2.

- Open the latch of the SIM card holder by sliding the retaining bracket toward OPEN.



- Flip the SIM card holder upward.
- The latch of the SIM card holder is open, now remove the SIM card SMC.



- To install the SIM card, proceed in the reverse order.



## Replacing the RF-Board (A200)

(see drawing 1411.4002.01).

### Removing the RF-Board

**Note:**

If the R&S SMC-B1 (Reference Oscillator) option is installed, uninstall this option first (see page 3.66)

- Switch off the instrument and pull the mains plug.
- Dismounting the tube (see page 3.31).
- Slice up the two cable ties 0015.9038.00 (208) and disconnect the cables W214 Mod Ext – RF Board 1406.8149.00 (650), the W215 LF- RF Board 1406.8132.00 (660) and W212 (630) and the cable BB–RF Board W222 1406.8110.00 (440).

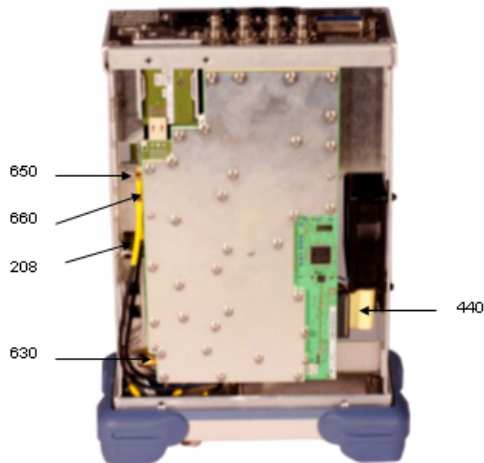

- Remove the 4 nuts of the BNC-connectors.

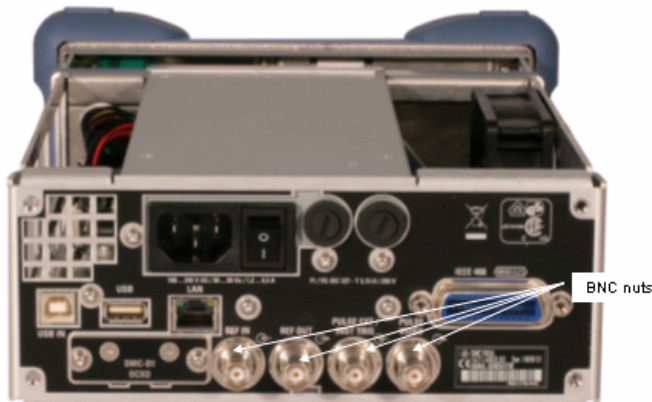

- Unscrew the 5 screws 1148.2869.00 (260) from the RF-board A 200 1411.4402.0 (250) and remove the board carefully.

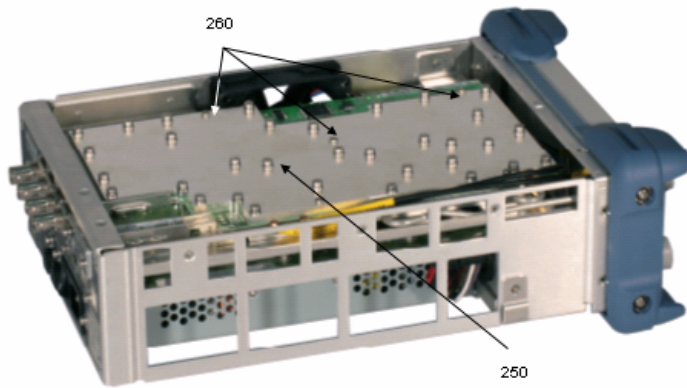

## Installing the RF-Board

- Place the RF-Board A200 1411.4402.02 (250) into the SMC in the right position and fix it with 5 screws 1148.2869.00 (260).

### NOTICE

Do not screw down the 5 screws, just fix them and after fixing the 4 BNC-Connector nuts you can screw down the 5 screws.

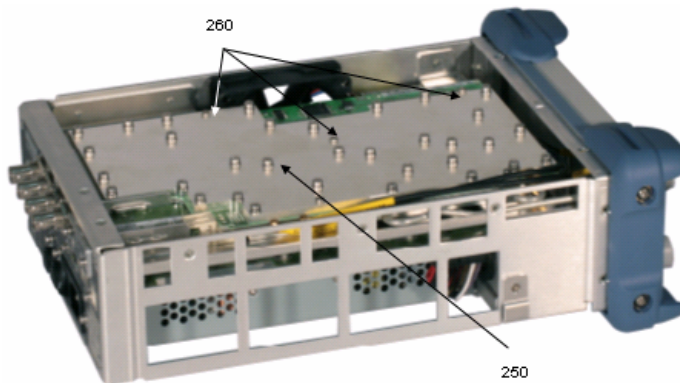

- Fix the 4 BNC-Connectors with the nuts.
- Screw the 5 screws 1148.2869.00 (260) and then screw the 4 BNC-Connectors with the nuts.

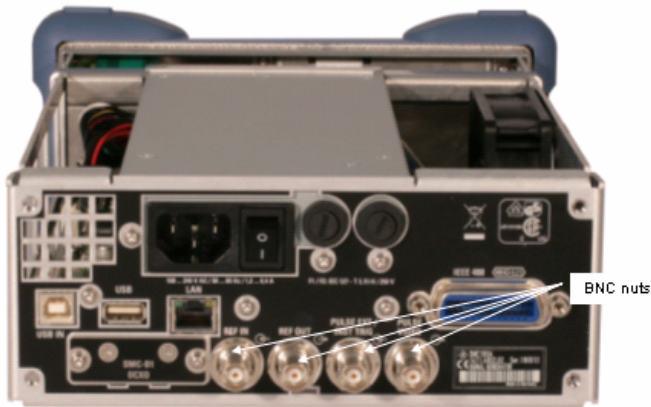

- Connect the Cables W214 Mod Ext – RF Board 1406.8149.00 (420), W215 LF –RF Board 1406.8132.00 (43), W212 1411.4390.00 (630) and the cable BB-RF-Board W222 1406.8110.00 (440).

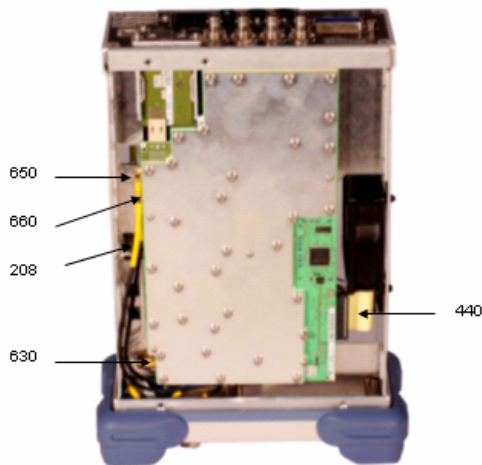

- Mounting the tube ( see page [3.32](#))

## Replacing the Fan Unit (E1)

(see drawing 1411.4002.01 and 1411.4348.01).

### Removing the Fan Unit (E1)

- Switch off the instrument and pull the mains plug.
- Dismounting the tube (see page 3.31).
- Disconnect the fan cable at X 116 and push the rubber pins (1146.2161.00) through the trough.

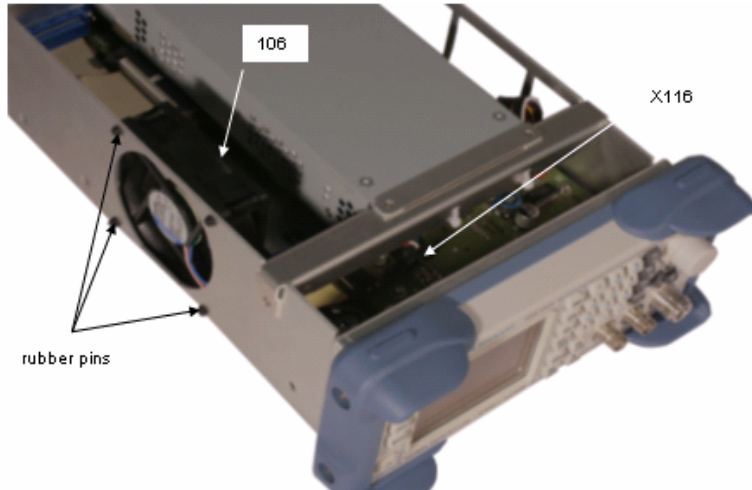

- Pull the fan unit E1 1406.6330.00 (106) upwards.

### Install the Fan Unit (E1)

- Install the new fan and proceed in the reverse order.
- Cut off the unnecessary rubber from the pins which extend outside the instrument casing.

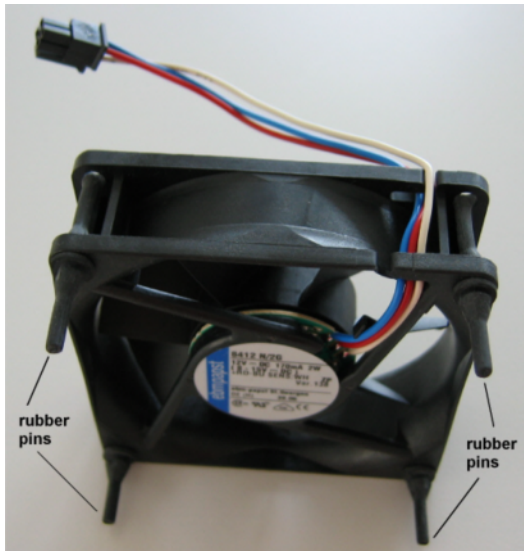

Fan Unit E1 1406.6330.00 (106), see also "Overview of the Modules", page 3.28.

# Replacing the SMC – B1

## Install the SMC – B1

- Switch off the instrument and pull the mains plug.
- Unscrew the two combinations screws 0041.1653.00 (508) and remove the rear panel 2 1411.4302.00 (507).

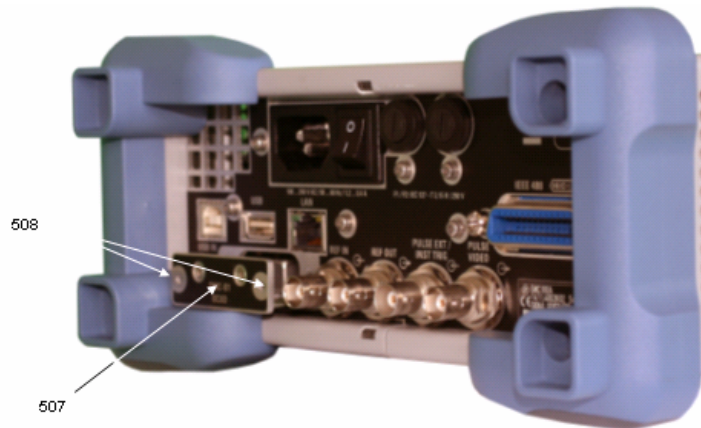

- Carefully move the reference oscillator SMC – B1 forwards.



- Screw the reference oscillator SMC – B1 with the 2 combinations screws 0041.1653.00 (508).

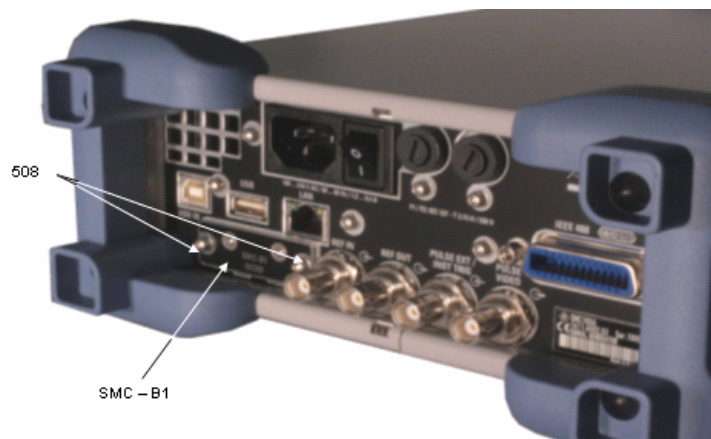

## **Remove the Reference Oscillator SMC-B1**

- Unscrew the 2 combinations screws 0041.1653.00 (508).
- Carefully remove the reference oscillator SMC – B1 backwards (see pic. SMC-B1)

# Contents - Chapter 4 "Software Update/Installing Options"

- 4 Software Update / Installing Options..... 4.1**
  - Installation of New R&S SMC Firmware.....4.1**
  - Installing the Options.....4.2**
    - Hardware Options .....4.2
    - Software Options.....4.3





## 4 Software Update / Installing Options

This chapter contains information on firmware update, Linux operating system update and installing options to the R&S SMC. Additional manuals obtained together with a firmware update or with subsequently acquired options can be filed here.

**NOTICE****Possible impairment of the functioning of the instrument**

The instrument is equipped with the Linux operating system. It is thus possible to install COTS software in the instrument. The use and installation of commercial off-the-shelf (COTS) software may impair the instrument function. For this reason, we recommend that you only execute programs tested by Rohde&Schwarz with regard to their compatibility with the instrument software. In certain cases, the use of these programs can impair the performance of the instrument.

The drivers and programs used in the instrument under Linux have been adapted to the test instrument. Existing instrument software must only be modified with update software released by Rohde & Schwarz.

### Installation of New R&S SMC Firmware

Your R&S SMC is delivered with the latest firmware version available. Firmware updates as well as the Release Notes describing the improvements and modifications are provided on the Internet at the download site of the R&S SMC homepage <http://www.rohde-schwarz.com/product/smc100a>. This homepage always offers the latest information on your signal generator, e.g. also on **changes of the firmware update procedure**.

Firmware updates always are delivered in one single file with a filename starting with "SMC\_" and ending in ".rsu". The version numbers in the filename vary with each update.

Firmware update: SMC\_x.xx.xx.rsu

The installation of a new firmware version is performed via the USB interface. A deinstallation of the old firmware is not necessary.

The update file has to be downloaded from the Internet to a PC. From there the file should be transferred to the root directory of a memory stick which will later be plugged into the USB interface of the instrument. The firmware update is performed while the instrument is running. The new firmware will be loaded right after the update process. If the instrument "sees" a memory stick at its USB interface, it offers all versions stored in the root directory for selection. Thus, an upgrade or downgrade of the firmware is possible at any time.

#### Installing the firmware

**NOTICE****Risk of impairment of instrument function!**

To avoid impairment of instrument functions, the update of the firmware must not be cancelled and the instrument must not be switched off during the update.

It is strongly recommended to do no downgrade below the firmware version the instrument has been delivered with.

1. Switch on the instrument and wait until it is operational.
2. Plug in the memory stick which contains the update file (previously downloaded from the Internet) to the USB interface of the instrument.
3. Wait until the software update dialog appears and confirm the update.
4. Select the firmware version to be installed with the cursor up/down keys and press the rotary knob to activate your selection. The selected version will be installed.
5. Wait until the software update completed message appears.
6. Remove USB stick and press the rotary knob to shut down instrument.
7. Power on instrument by pressing the power button.
8. When the new/updated firmware is up and running, execute internal adjustments after a warmup time of approx. 10 minutes.
  - Press the **SETUP** key on the instrument front panel, select **Internal Adjustments** and execute **Adjust All**.  
This process updates internal instrument adjustments and can take several minutes. Adjustments requiring external measurement equipment are not affected by the firmware update and need not to be performed.

## Installing the Options

A list of all available R&S SMC options is provided in the data sheet and on the internet <http://www.rohde-schwarz.com/product/smc100a>.

### Hardware Options

Installation and replacement of hardware options is described in chapter 3 of this service manual.

Please also note the mounting instructions enclosed with the options. These mounting instructions can be filed at this place in the service manual and are thus easily available whenever they are required.

#### CAUTION



#### Danger of shock hazard

For module replacement, ensure that the instrument is switched off and disconnected from the power supply by removing the plug from the AC and DC power connector. Read all safety instructions at the beginning of this manual carefully before module replacement!

#### NOTICE

#### Danger of damage to components of the module

Protect the operational site against electrostatic discharge to avoid damage to electronic components of the modules. For details refer to the safety instructions at the beginning of this manual.

The **SETUP** **Installed Options** menu provides information on the already installed options.

### Software Options

All available software options are already included in the latest firmware. They are ready to operate after they are enabled by means of a key code supplied with the option.

Only if the R&S SMC is equipped with an older firmware version, a firmware update prior to enabling the software option may be required. The information on the valid firmware versions for the purchased software option is provided together with the option.

The key code is to be entered into the **SETUP** **Install SW Option** menu.

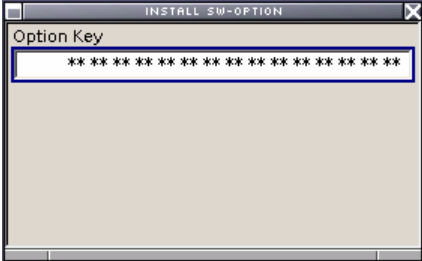

The **SETUP** **Installed Options** menu provides information on the already installed options



# Contents - Chapter 5 "Documents"

- 5 Documents.....5.1
  - Spare Parts.....5.1
  - Available Power Cables .....5.2



## 5 Documents

This chapter provides information on the ordering of spare parts and contains the documents for the complete R&S SMC unit.

### Spare Parts

The stock numbers necessary for ordering replacement parts and modules can be found in the component lists further down.

**CAUTION****Danger of shock hazard**

For module replacement, ensure that the instrument is switched off and disconnected from the power supply by removing the plug from the AC and DC power connector.

Read all safety instructions at the beginning of this manual carefully before module replacement!

**NOTICE****Risk of damage to the module**

When shipping a module be careful to provide for sufficient mechanical and anti-static protection.



## Available Power Cables

Table 5-1 List of power cables available

Stock No.	Earthed-contact connector	Preferably used in
DS 0006.7013.00	BS1363: 1967' 10 A, 250 V complying with IEC 83: 1975 standard B2	Great Britain
DS 0006.7020.00	Type 12, 10 A, 250 V complying with SEV-regulation 1011.1059, standard sheet S 24 507	Switzerland
DS 0006.7036.00	Type 498/13, 10 A, 250 V complying with US-regulation UL 498, or with IEC 83	USA/Canada
DS 0041.4752.00	GB2099, GB1002, 10 A, 250 V approvals CCC	China
DS 0041.6232.00	JIS C 8303, 7A, 125 V AC approvals PSE (JET)	Japan
DS 0006.7107.00	Type SAA3, 10 A, 250 V, complying with AS C112-1964 Ap.	Australia
DS 0025.2365.00 DS 0099.1456.00	DIN 49 441, 10 A, 250 V, angular DIN 49 441, 10 A, 250 V, straight approvals VDE, ÖVE, CEBEC, KEMA, S, D, N, FI, LCIE, IMQ, UCIEE	Europe (except Switzerland)

## **R&S SMC100A**

### **Spare Parts List**

Für diese Unterlage behalten wir uns alle Rechte vor.  
 Ausgedruckte Dokumente unterliegen nicht dem Änderungsdienst.  
 For this document all rights are reserved.  
 Printed documents are not subject to revision

Pos.-Nr. ItemNo	Menge Quantity	ME Unit	El.Kennz Ref.Des.	Benennung / Bezeichnung Designation	Z	Sachnummer Stock No.	Ersatzteil Subst.part	BA	VH
				ACHTUNG EGB/ATTENTION ESD *VARIANTENERKLAERUNG *EXPLANATION OF MODELS  VAR02=GRUNDVARIANTE MOD02=BASIC MODEL					
7 0		S		PB ERSATZTEILLISTE VORHANDEN SPARE PARTS LIST AVAILABLE Ersatzteilliste SMC ID.Nr. 1411.4031.01 ST		0999.9684.00		M	O
100 1		S		ZM CHASSIS SMC CHASSIS SMC	Z	1411.4348.02		M	
150 1		S	A100	ED BASISBOARD 2 BASIS BOARD 2	Z	1406.6700.04	X	M	
155 1		S	A110	HS CHIPKARTE SMC100A CHIPCARD SMC100A	Z	1411.4883.00		M	
160 10		S		VS 6900/ISR-M2.5X8-A2 COMBINATION SCREWS		0041.1653.00		B	T
170 1		S		MZ USB / NETZTEILWINKEL USB/POWER SUPPLY HOLDER	Z	1411.4331.00		M	
180 2		S		VS 7985/ISR-M3X6-A4-PA SCREW		1148.2630.00		B	O
200 1		S	A50	GJ SCHALTNETZTEIL AC90-264V POWER SUPPLY		1406.7336.00	X	B	B
204 1		S		MZ NETZTEILHALTERUNG 1/2 POWER SUPPLY HOLDER	Z	1411.4277.00		M	
206 2		S		VS 965/ISR-M2.5X4-A4-PA 965/ISR-M2.5X4-A4-PA		1148.3271.00		B	T
207 1		S		MZ UNTERLEGBELCH HOLDER	Z	1411.4260.00		M	
208 3		S		DZ KABELBI.RD 1 BIS 25 B2 CABLETIE		0015.9038.00		B	O
210 2		S		VS 965/ISR-M2X5-A4-PA 965/ISR-M2X5-A4-PA		1148.3265.00		B	O
250 1		S	A200	ED RF BOARD RF BOARD	Z	1411.4402.02	X	M	
260 5		S		VS 7985/ISR-M2.5X16-A4-PA 7985/ISR-M2.5X16-A4-PA		1148.2869.00		B	T
400 1		S	A300	ZM FRONTEINHEIT SMC FRONT UNIT SMC	Z	1411.4602.02	X	M	
401 4		S		VS 965/ISR-M2.5X4-A4-PA 965/ISR-M2.5X4-A4-PA		1148.3271.00		B	T
440 1		S	W222	DY KABEL BB-RF-BOARD CABLE BB-RF-BOARD	Z	1406.8110.00		M	
500 1		S		KB FRONTHAUBE SMC BEDRUCKT FRONT COVER SMC PRINTED	Z	1411.4683.00		M	
507 1		S		KB RÜCKWAND 2 SMC BEDRUCKT REAR PANEL 2 SMC PRINTED	Z	1411.4302.00		M	
508 2		S		VS 6900/ISR-M2.5X8-A2 COMBINATION SCREWS		0041.1653.00		B	T
510 1		S		KR BW2 TUBUS 2E1/2T350 SMC100A BW2 TUBE 2HU1/2D350 SMC100A	Z	1411.4383.00		M	



**ROHDE & SCHWARZ**

Benennung/Designation

**SMC100A SIGNAL GENERATOR**  
**SMC100A SIGNAL GENERATOR**

Sprach./Lang

de en

Ä.I. / C.I

06.00

Blatt/Sheet

1 of 2

Dokument Nr. / Document No.

**1411.4002.01 ST**

SMC100A

Datum/  
Date

2008-07-18

Abt. /  
Dept.

1GPK

Name /  
Name

BU

Für diese Unterlage behalten wir uns alle Rechte vor.  
 Ausgedruckte Dokumente unterliegen nicht dem Änderungsdienst.  
 For this document all rights are reserved.  
 Printed documents are not subject to revision

Pos.-Nr. <i>ItemNo</i>	Menge <i>Quantity</i>	ME <i>Unit</i>	El.Kennz <i>Ref.Des.</i>	Benennung / Bezeichnung <i>Designation</i>	Z	Sachnummer <i>Stock No.</i>	Ersatzteil <i>Subst.part</i>	BA	VH
520	1	S		KR BW2-SCHUTZECK VO.LI.2E HART PROTECTIVE CORNER FRONT LEFT		1096.6618.00		B	O
530	1	S		KR BW2-SCHUTZECK VO.RE.2E HART PROTECTIVE CORNER FRONT RIGHT 2HU		1096.6624.00		B	O
540	1	S		KR BW2-SCHUTZECK HI.LI.2E HART PROTECTIVE COVER REAR LEFT 2HU		1096.6630.00		B	O
550	1	S		KR BW2-SCHUTZECK HI.RE.2E HART PROTECTIVE COVER REAR RIGHT 2HU		1096.6647.00		B	O
700	1	S		HS FIRMWARE SMC FIRMWARE SMC	Z	1411.4502.00		M	
710	1	S	W108	DY IEC BUS CABLE IEC BUS CABLE	Z	1411.4760.00		M	

	Benennung/ <i>Designation</i>			Sprach./Lang	Ä.I. / C./	Blatt/Sheet
	<b>SMC100A SIGNAL GENERATOR</b> <b>SMC100A SIGNAL GENERATOR</b>			de en	06.00	2 of 2
SMC100A	Datum/ <i>Date</i>	2008-07-18	Abt. / <i>Dept.</i>	1GPK	Name / <i>Name</i>	BU
Dokument Nr. / Document No.						<b>1411.4002.01 ST</b>

Für diese Unterlage behalten wir uns alle Rechte vor.  
 Ausgedruckte Dokumente unterliegen nicht dem Änderungsdienst.  
 For this document all rights are reserved.  
 Printed documents are not subject to revision

Pos.-Nr. ItemNo	Menge Quantity	ME Unit	El.Kennz Ref.Des.	Benennung / Bezeichnung Designation	Z	Sachnummer Stock No.	Ersatzteil Subst.part	BA	VH
				ACHTUNG EGB/ATTENTION ESD  *VARIANTENERKLAERUNG *EXPLANATION OF MODELS  VAR02=GRUNDVARIANTE MOD02=BASIC MODEL					
101	1	S		MZ HALTEWINKEL 1/2 HOLDER 1/2	Z	1411.4254.00		M	
102	1	S		KB GERAETEWANNE SMC BEDRUCKT REAR PANEL SMC BEDRUCKT	Z	1411.4319.00		M	
103	1	S		KR BW2-FRONTRAHMEN 2E 1/2 FRONTFRAME		1096.0355.00		M	T
104	12	S		VN BLINDNIET 3.2X5.8 ST BLIND RIVET 3.2X5.8 ST		1096.4821.00		B	O
105	1.2	M		WG HF-DICHT O-PROF 2.0 SI SEALING		0396.1035.00		B	T
106	1	S	E1	DX LUEFTEREINHEIT FAN UNIT	Z	1406.6330.00		M	
107	2	S		MZ Dichtungsfeder L=12.05 MZ SEAL SPRING L=12.05	Z	1143.8881.00		M	

 <b>ROHDE &amp; SCHWARZ</b>	Benennung/Designation <b>CHASSIS SMC</b> <b>CHASSIS SMC</b>			Sprach./Lang de en	Ä.I. / C./ 06.00	Blatt/Sheet 1 of 1
	Datum/ Date	2008-05-28	Abt. / Dept.	1GPK	Name / Name	MS

Für diese Unterlage behalten wir uns alle Rechte vor.  
 Ausgedruckte Dokumente unterliegen nicht dem Änderungsdienst.  
 For this document all rights are reserved.  
 Printed documents are not subject to revision

Pos.-Nr. ItemNo	Menge Quantity	ME Unit	El.Kennz Ref.Des.	Benennung / Bezeichnung Designation	Z	Sachnummer Stock No.	Ersatzteil Subst.part	BA	VH
				ACHTUNG EGB/ATTENTION ESD *VARIANTENERKLAERUNG *EXPLANATION OF MODELS  VAR02=GRUNDVARIANTE MOD02=BASIC MODEL					
402	1	S		MZ MONTAGEWANNE SMC MOUNTING THROUGH	Z	1411.4619.00		M	
403	1	S	A320	SF SCHALTFOLE SMC FLEX. SWITCH BOARD		1411.4660.00		B	B
404	1	S		SF SILIKONMATTE SMC PUSH-BUTTON BOARD SMC		1411.4654.00		B	O
405	1	S		ZM TASTATURRAHMEN MIT SCHEIBE KEY FRAME WITH PANE	Z	1411.4754.00		M	
406	10	S		VS 965/ISR-M2X5-A4-PA 965/ISR-M2X5-A4-PA		1148.3265.00		B	O
407	1	S		MZ STAUBABDICHTUNG SMC POWDER SEAL		1411.4690.00		M	
408	1	S	A330	BP TFT 3.5 QVGA DRGB LED TX09D70VM1CDA		1407.3586.00		B	B
409	1	S	W330	DF FLEX-STRIP.40P R=0.5 FLEX-STRIP.40P R=0.5		1411.4731.00		B	B
410	1	S		ZN DISPLAYHAUBE SMC V3 DISPLAY COVER SMC V3	Z	1411.4890.00		M	
411	1	S	A310	ED ENCODER BOARD ENCODER BOARD	Z	1300.3044.02		M	O
412	2	S		VS 6900/ISR-M2.5X6-A2 COMBINATION SCREWS		1148.3059.00		B	T
413	1	S	W310	DF FLEX-STRIP 10P. R=0.5 FLEX-STRIP		1146.9150.00		B	B
414	1	S		ZM FRONTANSCHLUSSPLATTE FRONT CONNECTOR PLATE	Z	1411.4748.00		M	
415	4	S		VS 965/ISR-M2X5-A4-PA 965/ISR-M2X5-A4-PA		1148.3265.00		B	O
416	1	S		OK DREHKNOPF RD20 - ACHSE RD6 KNOB		2112.6131.00		B	B



**ROHDE & SCHWARZ**

Benennung/Designation  
**FRONTEINHEIT SMC**  
**FRONT UNIT SMC**

Sprach./Lang  
de en

Ä.I. / C.I  
04.00

Blatt/Sheet  
1 of 1

Dokument Nr. / Document No.

**1411.4602.01 ST**

SMC

Datum/  
Date 2008-07-23

Abt. /  
Dept. 3TPK

Name /  
Name FIS

Für diese Unterlage behalten wir uns alle Rechte vor.  
 Ausgedruckte Dokumente unterliegen nicht dem Änderungsdienst.  
 For this document all rights are reserved.  
 Printed documents are not subject to revision

Pos.-Nr. ItemNo	Menge Quantity	ME Unit	El.Kennz Ref.Des.	Benennung / Bezeichnung Designation	Z	Sachnummer Stock No.	Ersatzteil Subst.part	BA	VH
				ACHTUNG EGB/ATTENTION ESD					
620	1	S		MF BUCHSENPLATTE SMC SOCKET PLATE SMC		1411.4648.00		M	
630	1	S	W212	DW HF KABEL W212 RF FRONT (L) HF CABLE W212 RF FRONT (L)	Z	1411.4390.00		M	
640	1	S		VS 7985/ISR-M2X4-A4-PA 7985/ISR-M2X4-A4-PA		1148.2698.00		B	O
645	1	S		VS DIN125-A2.5-A4 WASHER DIN125		0082.4657.00		B	V
650	1	S	W214	DV KABEL W214 MOD EXT - RFBOARD CABLE W214 MOD EXT - RFBOARD	Z	1406.8149.00		M	
660	1	S	W215	DV KABEL W215 LF - RFBOARD CABLE W215 LF - RFBOARD	Z	1406.8132.00		M	

 <b>ROHDE &amp; SCHWARZ</b>	Benennung/Designation <b>FRONTANSCHLUSSPLATTE</b> <b>FRONT CONNECTOR PLATE</b>			Sprach./Lang de en	Ä.I. / C./ 03.00	Blatt/Sheet 1 of 1
	Datum/ Date	2008-07-18	Abt. / Dept.	1GPK	Name / Name	WB

## **R&S SMC100A**

### **Mechanical Drawings**



Nicht dargestellt: Pos. 510 (Tubus)

Not shown: Pos. 510 (Tube)

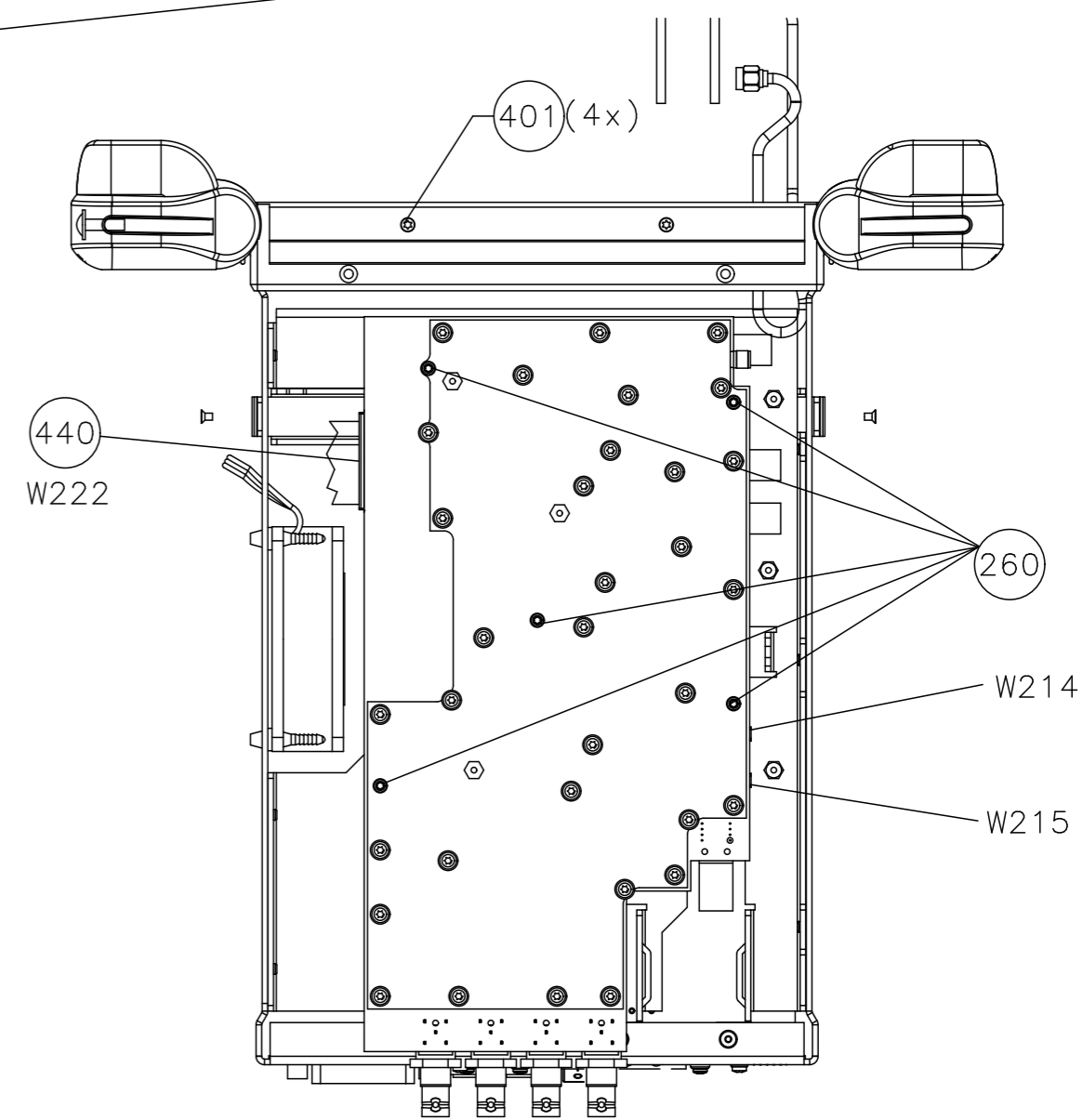
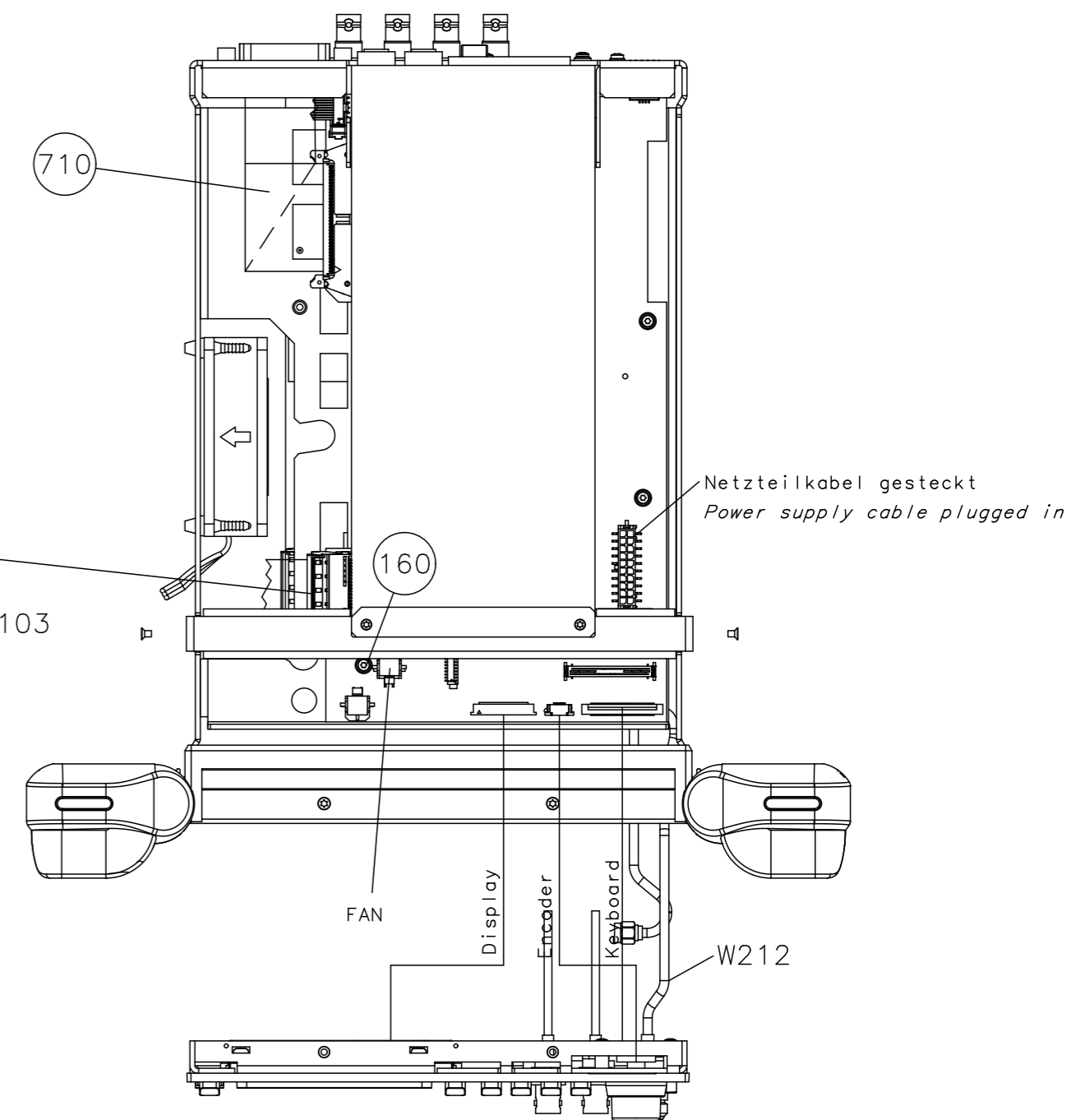
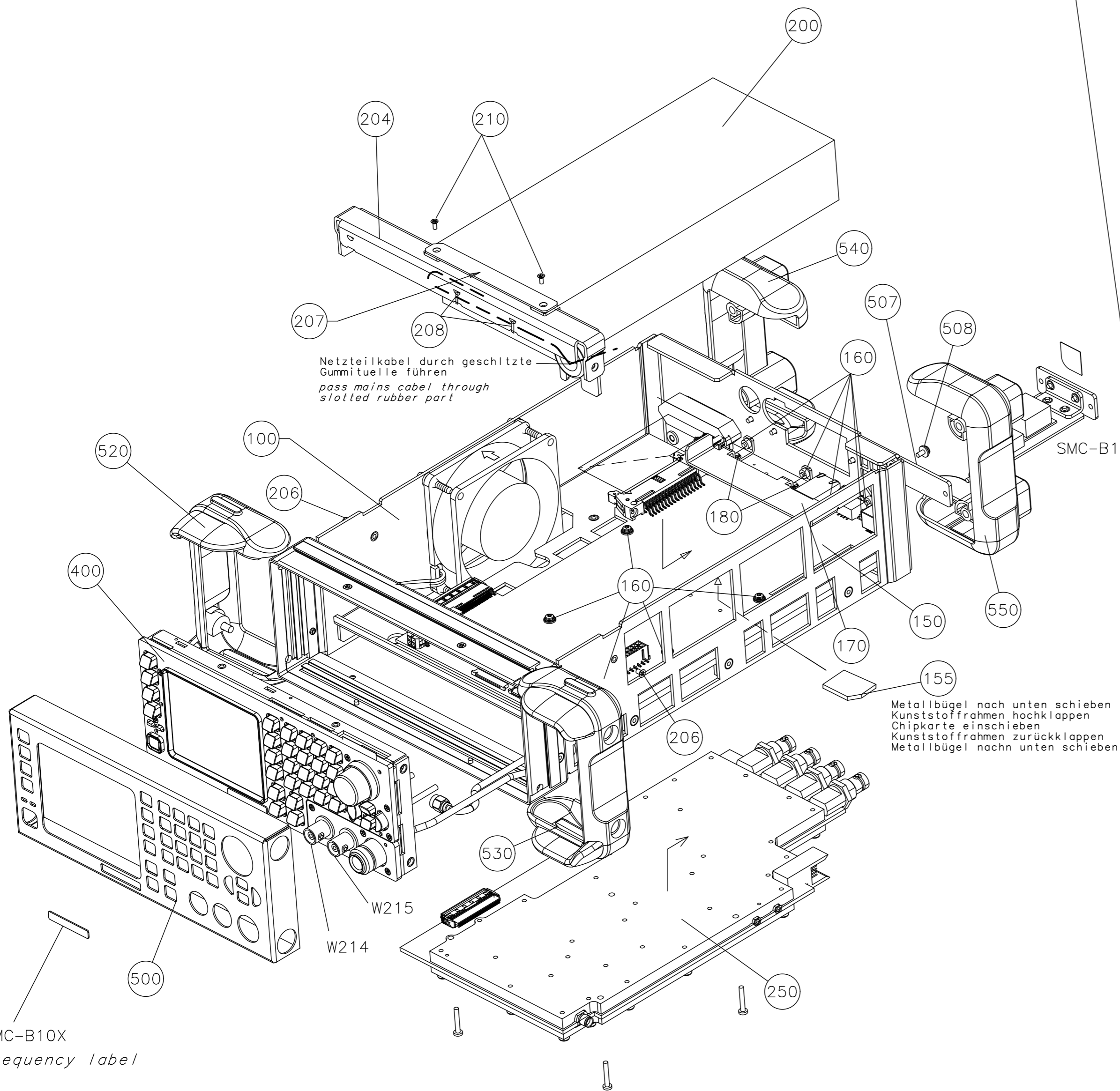

Maßstab Scale	Toleranz Tol.	Werkstoff Material	Sprache / Lang. Ael. / C.I.	Blatt / Sh.
ROHDE&SCHWARZ	Benennung / Designation	SMC100A SIGNAL GENERATOR SMC100A SIGNAL GENERATOR	de en	03.00 1
SMC100A	Datum Date	Abteilung Dept.	Name Name	ms
		16PK		1411.4002.01 D
				Zeichn.Nr. / Drawing No.

Für dieses Dokument behalten wir uns alle Rechte vor  
For this document all rights are reserved

Projektions-  
methode  
Projection  
Method

Für dieses Dokument behalten wir uns alle Rechte vor  
 For this document all rights are reserved

Projektions-  
 methode  
 Projection  
 Method

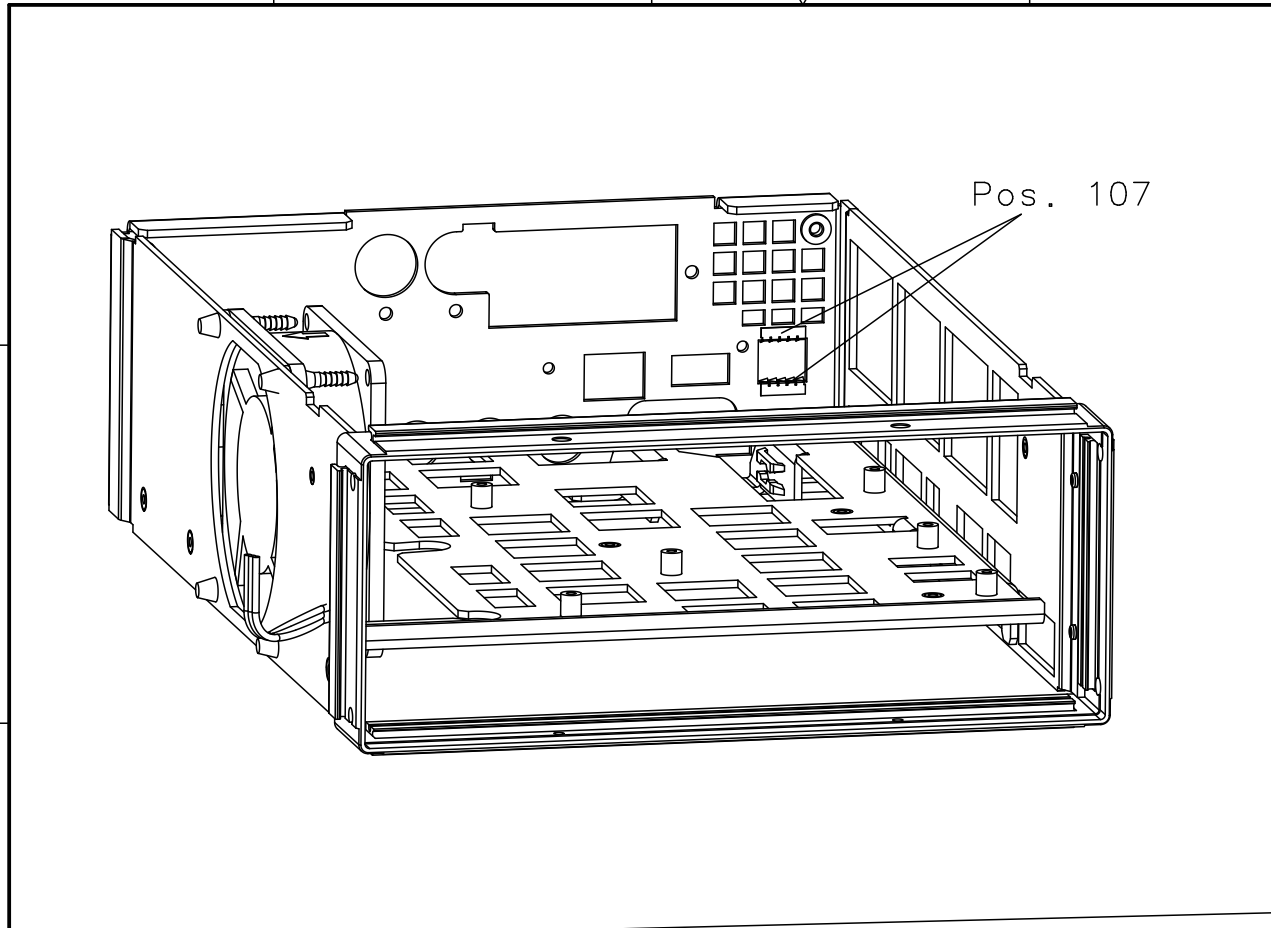

Ansicht von oben, rechts

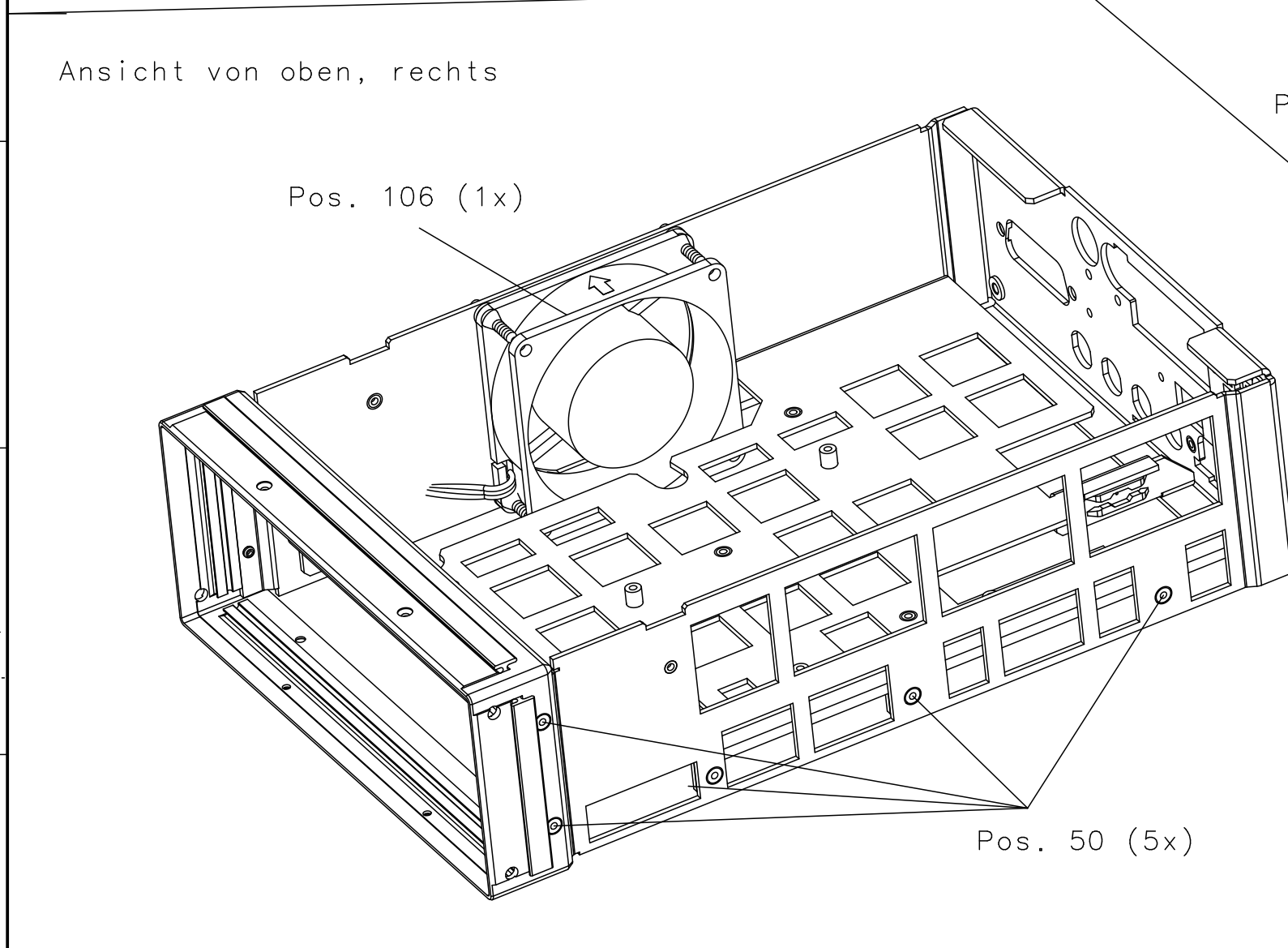

Ansicht von unten, links

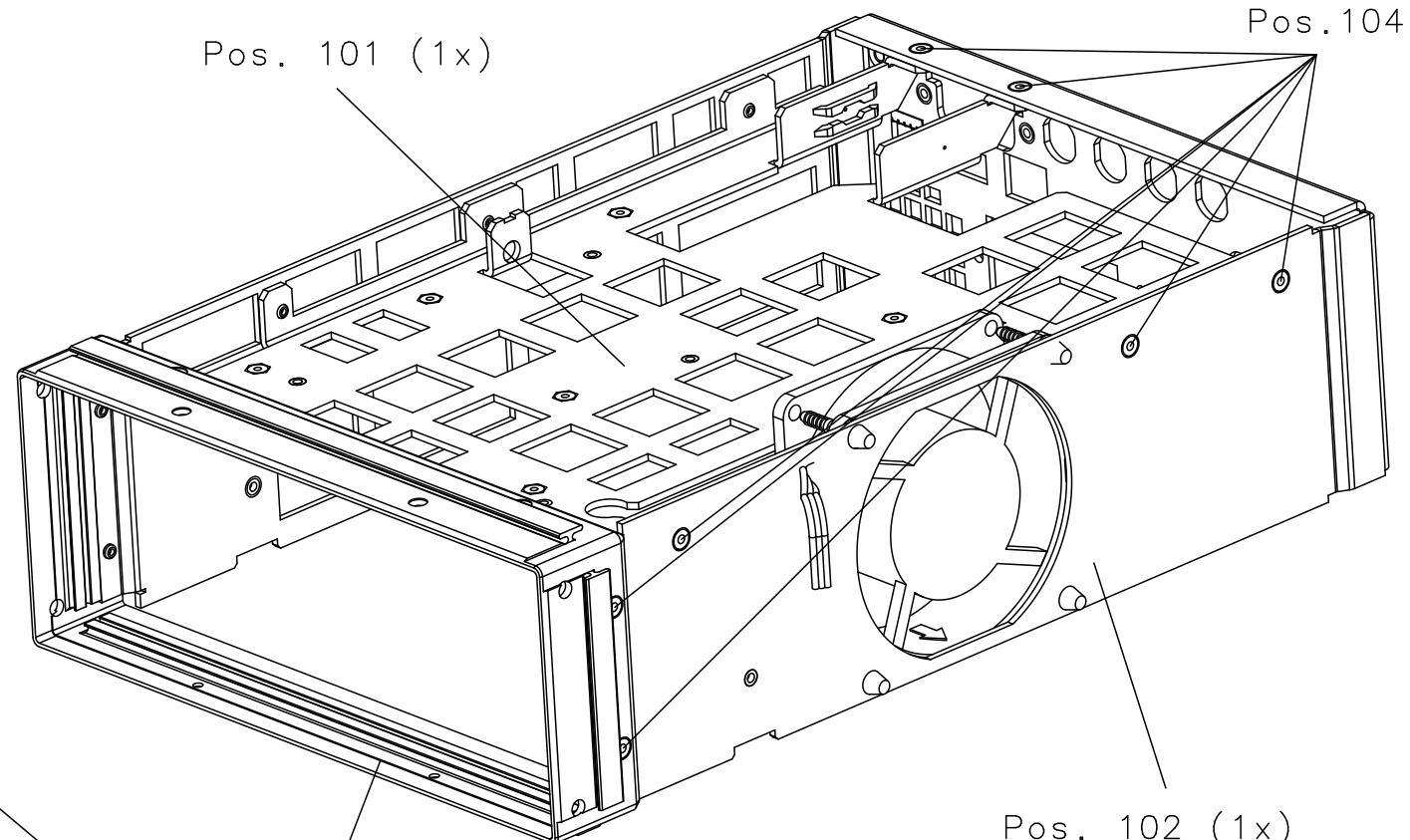

2x 0,6m Dichtschnur Pos.105  
 -Fronteinheit (innen, vorne)  
 -Tubuskontaktierung (aussen, hinten)  
 in jeweilige Nut eindrücken.  
 Enden mit kleinen Punkten  
 Silicon gegen Ausfransen sichern

Maßstab Scale	1:2	Toleranz Tol.	Werkstoff Material	Sprache / Lang. Ael. / C.I.	Blatt / Sh.
ROHDE&SCHWARZ		CHASSIS SMC CHASSIS SMC		de en	05.00
Datum Date	2008-02-28	Abteilung Dept.	1GPK	Zeichn.Nr. / Drawing No.	1411.4348.01
			Name Name	ms	D

Für dieses Dokument behalten wir uns alle Rechte vor  
For this document all rights are reserved

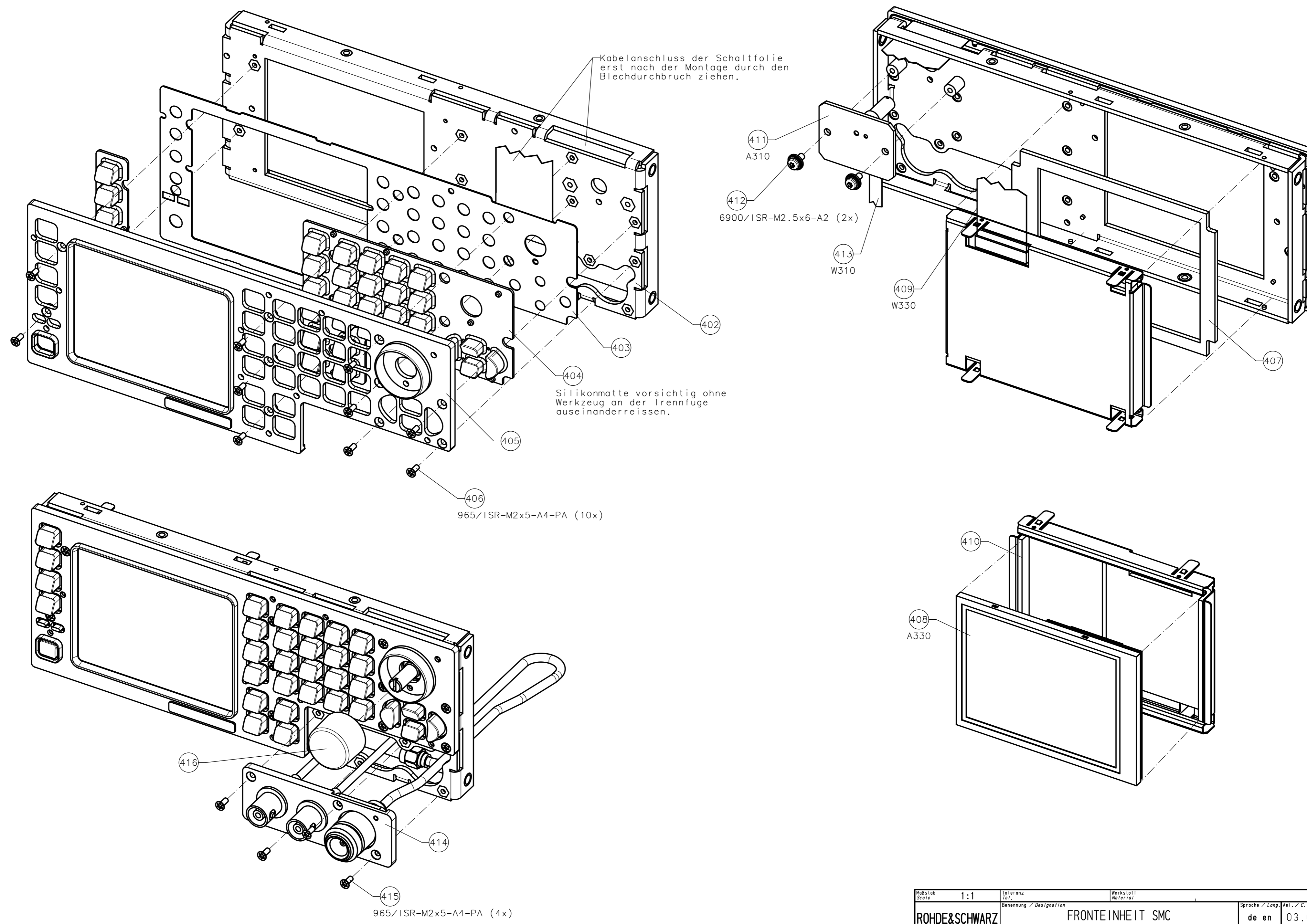

Kabelanschluss der Schaltfolie  
erst nach der Montage durch den  
Blechdurchbruch ziehen.

Silikonmatte vorsichtig ohne  
Werkzeug an der Trennfuge  
auseinanderreißen.

965/ISR-M2x5-A4-PA (10x)

965/ISR-M2x5-A4-PA (4x)

411  
A310

412  
6900/ISR-M2.5x6-A2 (2x)

413  
W310

409  
W330

408  
A330

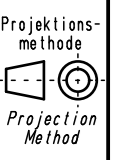

Maßstab Scale	1:1	Toleranz Tol.	Werkstoff Material	Sprache / Lang. Ael. / C.F.	Blatt / Sh.
ROHDE&SCHWARZ		FRONTEINHEIT SMC FRONT UNIT SMC		de en	03.00
SMC		Datum Date	2008-05-05	Abteilung Dept.	1ZKS
		Name	Wb	Zeichn.Nr. / Drawing No.	1411.4602.01
					D

Für dieses Dokument behalten wir uns alle Rechte vor  
 For this document all rights are reserved

Projektions-  
 methode  
  
 Projection  
 Method

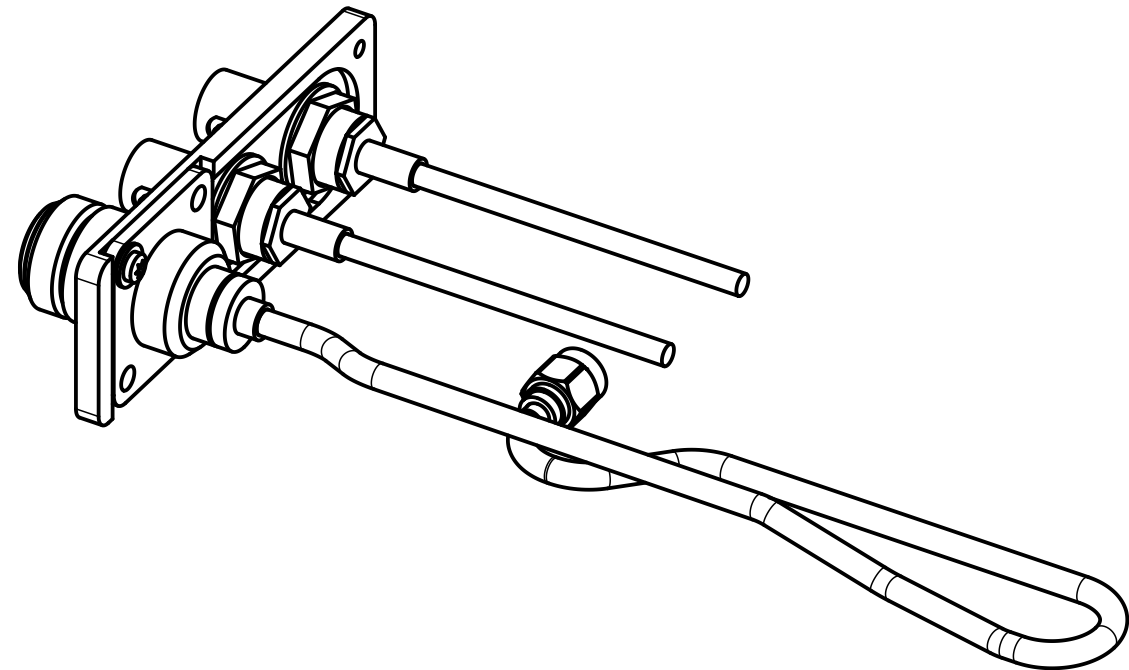
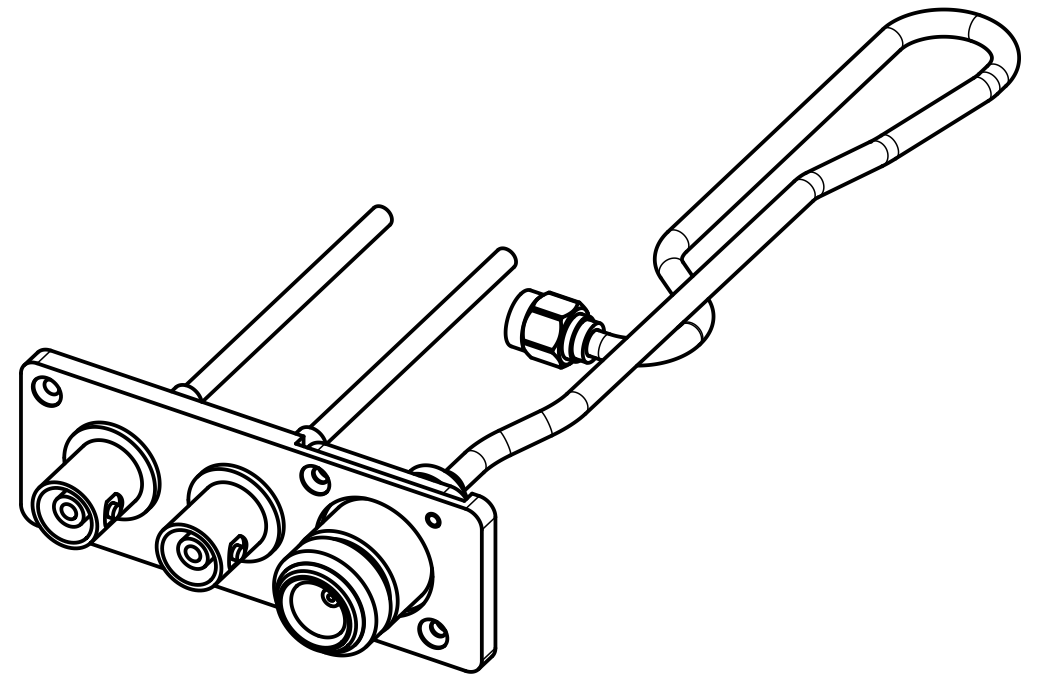
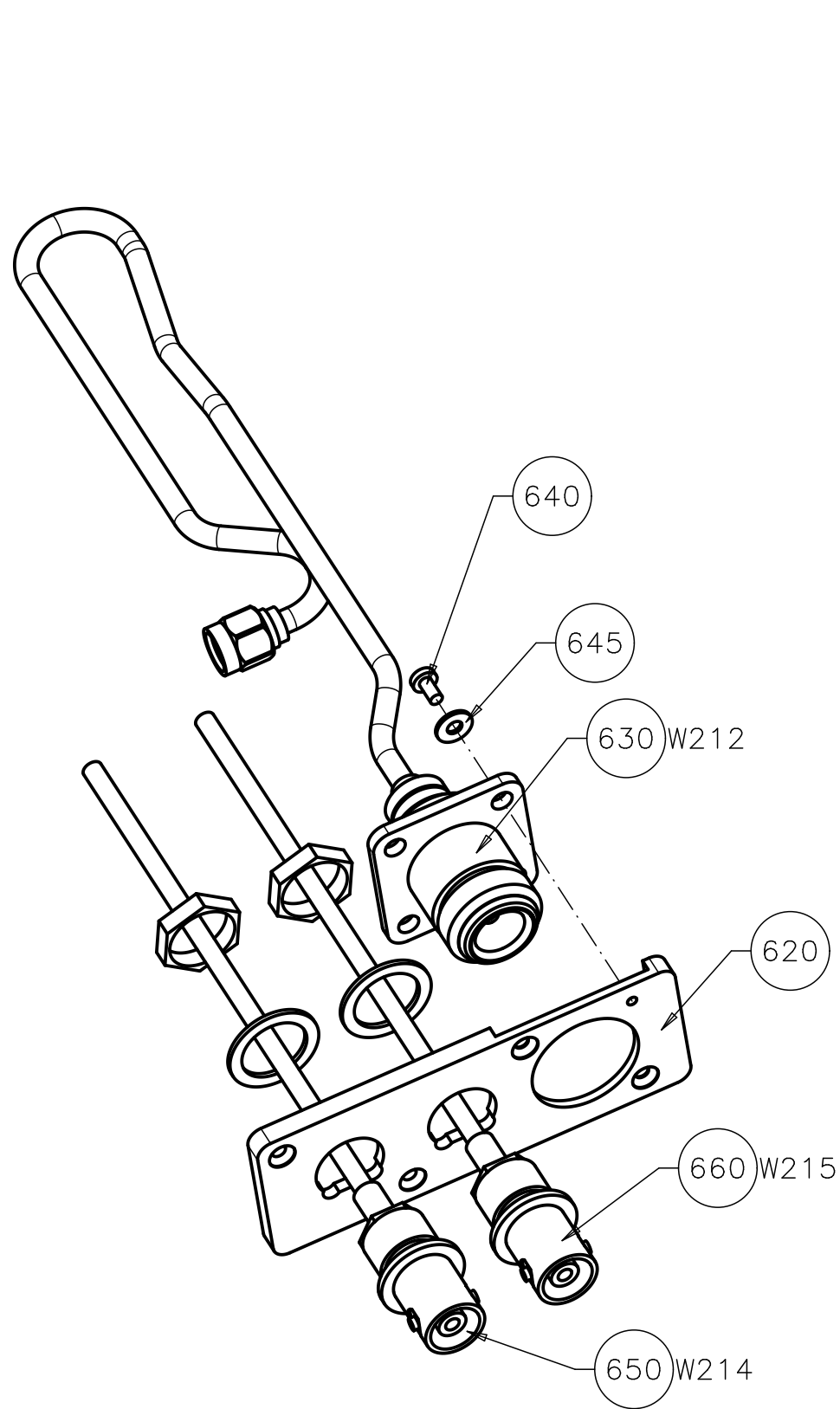

Maßstab Scale	Toleranz Tol.	Werkstoff Material	Sprache / Lang. Ael. / C.I.		Blatt / Sh.
ROHDE&SCHWARZ	Benennung / Designation FRONTANSCHLUSSPLATTE FRONT CONNECTOR PLATE		de en	03.00	1
Datum Date	2008-05-28	Abteilung Dept.	1ZKS	Name Name	Wb
Zeichn.Nr. / Drawing No.			1411.4748.00 D		